

# TQSOT



## Service Manual



## Table of Contents

<b>Part I : Technical Information</b> .....	1
<b>1. Summary</b> .....	1
<b>2. Specifications</b> .....	2
2.1 Specification Sheet.....	2
2.2 Operation Characteristic Curve.....	4
2.3 Capacity Variation Ratio According to Temperature.....	4
2.4 Cooling and Heating Data Sheet in Rated Frequency.....	5
2.5 Noise Curve.....	5
<b>3. Outline Dimension Diagram</b> .....	6
3.1 Indoor Unit.....	6
3.2 Outdoor Unit.....	7
<b>4. Refrigerant System Diagram</b> .....	8
<b>5. Electrical Part</b> .....	9
5.1 Wiring Diagram.....	9
5.2 PCB Printed Diagram.....	11
<b>6. Function and Control</b> .....	13
6.1 Remote Controller Introduction.....	13
6.2 Ewpe Smart App Operation Manual.....	18
6.3 Brief Description of Modes and Functions.....	19
<b>Part II : Installation and Maintenance</b> .....	28
<b>7. Notes for Installation and Maintenance</b> .....	28
<b>8. Installation</b> .....	31
8.1 Installation Dimension Diagram.....	31
8.2 Installation Parts-checking.....	33
8.3 Selection of Installation Location.....	33
8.4 Requirements for Electric Connection.....	33
8.5 Installation of Indoor Unit.....	33
8.6 Installation of Outdoor Unit.....	36
8.7 Vacuum Pumping and Leak Detection.....	37
8.8 Check after Installation and Test Operation.....	37

<b>9. Maintenance</b> .....	38
9.1 Error Code List .....	38
9.2 Troubleshooting for Main Malfunction .....	45
9.3 Troubleshooting for Normal Malfunction.....	58
<b>10. Exploded View and Parts List</b> .....	60
10.1 Indoor Unit.....	60
10.2 Outdoor Unit.....	62
<b>11. Removal Procedure</b> .....	64
11.1 Removal Procedure of Indoor Unit .....	64
11.2 Removal Procedure of Outdoor Unit .....	69
<b>Appendix:</b> .....	74
Appendix 1: Reference Sheet of Celsius and Fahrenheit .....	74
Appendix 2: Configuration of Connection Pipe.....	74
Appendix 3: Pipe Expanding Method .....	75
Appendix 4: List of Resistance for Temperature Sensor .....	76





## 2. Specifications

### 2.1 Specification Sheet

Model		TW09HQ3C2D(WIFI)	TW12HQ3C2D(WIFI)
Product Code		CB439011200_X40891	CB439011300_X40891
Power Supply	Rated Voltage	V~	208/230
	Rated Frequency	Hz	60
	Phases		1
Power Supply Mode		Outdoor	Outdoor
Cooling Capacity(Min~Max)	Btu/h	9000(909~9600)	12000(3753~12500)
Heating Capacity(Min~Max)	Btu/h	9500(3100~12000)	13000(3924~14000)
Cooling Power Input(Min~Max)	W	850(375~1300)	1150(410~1350)
Heating Power Input(Min~Max)	W	850(300~1350)	1250(380~1500)
Cooling Power Current	A	4.0	5.1
Heating Power Current	A	3.8	5.55
Rated Input	W	1350	1500
Rated Current	A	6.0	6.88
Air Flow Volume(SH/H/M/L)	CFM	318/288/241/171	400/318/253/194
Dehumidifying Volume	Pint/h	1.69	2.96
EER	(Btu/h)/W	10.59	10.43
COP	(Btu/h)/W	11.18	10.4
SEER		18.00	18.00
HSPF		9.00	9.00
Application Area	yd <sup>2</sup>	19.14-28.70	19.14-28.70
Indoor Unit	Model of indoor unit		TW09HQ3C2DI
	Fan Type		Cross-flow
	Diameter Length(DXL)	inch	Φ3 55/64X22 5/6
	Fan Motor Cooling Speed(SH/H/M/L)	r/min	1350/1200/1050/750
	Fan Motor Heating Speed(SH/H/M/L)	r/min	1350/1200/1050/850
	Output of Fan Motor	W	20
	Fan Motor RLA	A	0.22
	Fan Motor Capacitor	μF	1
	Evaporator Form		Aluminum Fin-copper Tube
	Pipe Diameter	inch	Φ13/64
	Row-fin Gap	inch	2-1/16
	Coil Length (LXDXW)	inch	23X7/8X10 8/16
	Swing Motor Model		MP24AA
	Output of Swing Motor	W	1.5
	Fuse	A	3.15
	Sound Pressure Level(SH/H/M/L)	dB (A)	43/38/34/28
	Sound Power Level(SH/H/M/L)	dB (A)	53/49/45/39
	Dimension (WXHXD)	inch	31 7/64X10 5/6X7 7/8
	Dimension of Carton Box (LXWXH)	inch	34X10 35/64X13 55/64
	Dimension of Package (LXWXH)	inch	34X10 21/32X14 29/64
Net Weight	lb	20.9	
Gross Weight	lb	25.4	

		TW09HQ3C2DO	TW12HQ3C2DO
Model of Outdoor Unit		TW09HQ3C2DO	TW12HQ3C2DO
Outdoor Unit Product Code		CB425W08500_X40891	CB425W08100_X40891
Compressor Manufacturer/Trademark		ZHUHAI GREE DAIKIN DEVICE CO.,LTD	ZHUHAI LAMDA COMPRESSOR CO.,LTD.
Compressor Model		RB68EP	QXA-B102zE190
Compressor Oil		DAPHNE FVC50K	RB68EP
Compressor Type		Rotary	Rotary
Compressor Locked Rotor Amp (L.R.A)	A	/	/
Compressor RLA	A	6.6	6.6
Compressor Power Input	W	1020	1020
Overload Protector		1NT11L-6233 or HPC115/95U1 or KSD115 C	1NT11L-6233 or HPC115/95U1 or KSD115°C
Throttling Method		Electric Expansion Valve Sub-Assy	Electron expansion valve
Operation temp	°F	60.8~86	60.8~86
Ambient temp (cooling)	°F	0~115	0~115
Ambient temp (heating)	°F	-13~75	-4~75
Condenser Form		Aluminum Fin-copper Tube	Aluminum Fin-copper Tube
Pipe Diameter	inch	Φ9/32	Φ5/16
Rows-fin Gap	inch	1-1/18	2-1/16
Coil Length (LXDXW)	inch	28X3/4X20	28X1 1/2X20
Fan Motor Speed	rpm	900	900
Output of Fan Motor	W	30	30
Fan Motor RLA	A	0.36	0.37
Fan Motor Capacitor	μF	/	/
Air Flow Volume of Outdoor Unit	CFM	942	1600
Fan Type		Axial-flow	Axial-flow
Fan Diameter	inch	Φ15 3/4	Φ15 3/4
Defrosting Method		Automatic Defrosting	Automatic Defrosting
Climate Type		T1	T1
Isolation		I	I
Moisture Protection		IPX4	IPX4
Permissible Excessive Operating Pressure for the Discharge Side	PSIG	550	550
Permissible Excessive Operating Pressure for the Suction Side	PSIG	240	240
Sound Pressure Level (H/M/L)	dB (A)	52/-/-	53/-/-
Sound Power Level (H/M/L)	dB (A)	62/-/-	63/-/-
Dimension (WXHXD)	inch	30 9/16X21 1/4X12 5/8	30 9/16X21 1/4X12 5/8
Dimension of Carton Box (LXWXH)	inch	32 9/32X13 63/64X22 27/32	32 9/32X13 63/64X22 27/32
Dimension of Package (LXWXH)	inch	32 13/32X14 3/32X23 27/64	32 13/32X14 3/32X23 27/64
Net Weight	lb	63.9	69.45
Gross Weight	lb	69.5	74.96
Refrigerant		R410A	R410A
Refrigerant Charge	oz	24.7	31.8
Length	ft	24.6	24.6
Gas Additional Charge	oz/ft	0.2	0.2
Outer Diameter Liquid Pipe	inch	Φ1/4	Φ1/4
Outer Diameter Gas Pipe	inch	Φ3/8	Φ3/8
Max Distance Height	ft	65	65
Max Distance Length	ft	100	100
Note:The connection pipe applies metric diameter.			

The above data is subject to change without notice. Please refer to the nameplate of the unit.

## 2.2 Operation Characteristic Curve

**Cooling**

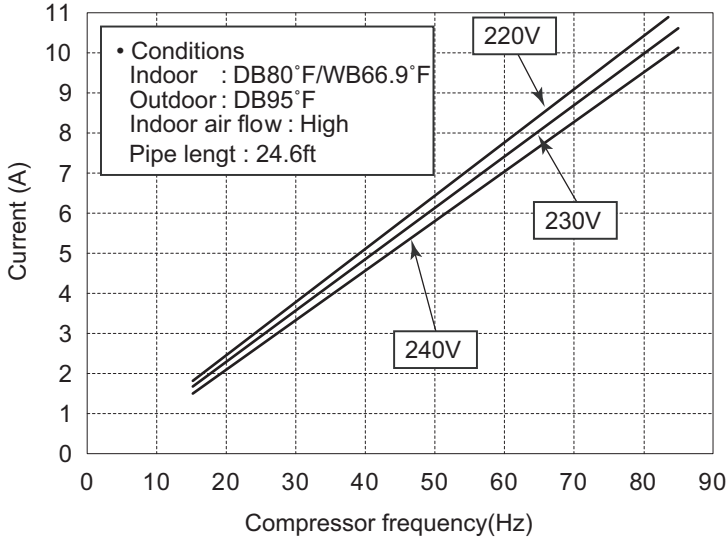

**Heating**

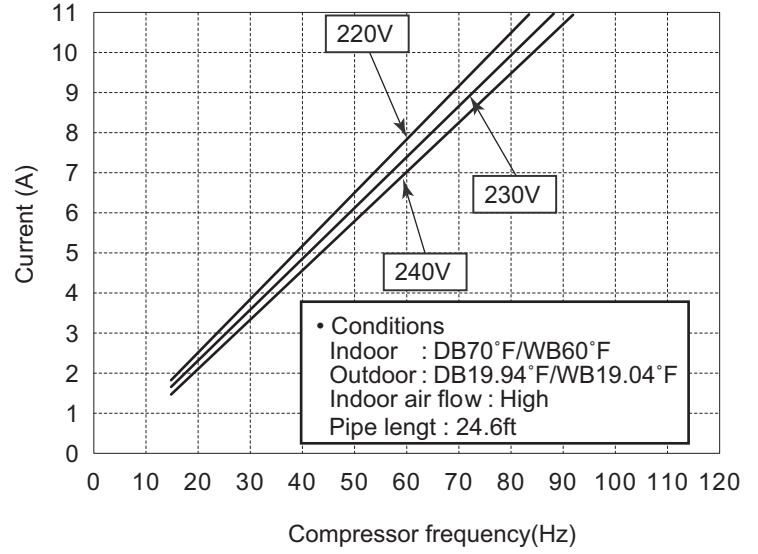

## 2.3 Capacity Variation Ratio According to Temperature

**Cooling**

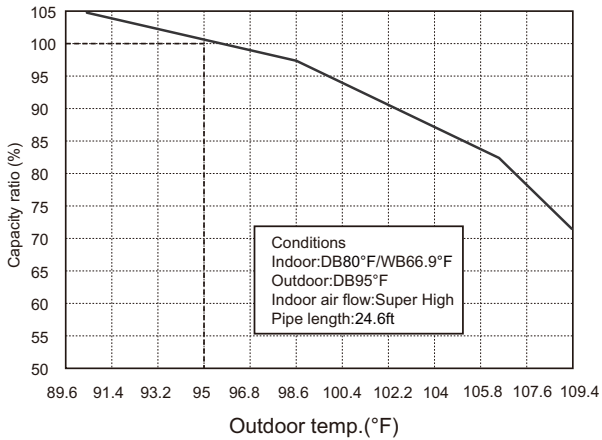

TW12HQ3C2DO

**Heating**

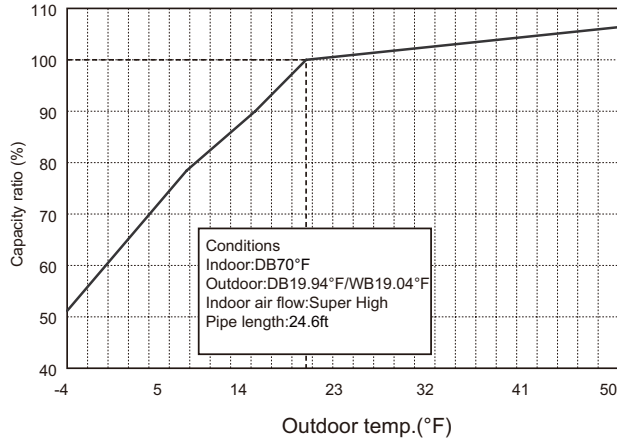

TW09HQ3C2DO

**Heating**

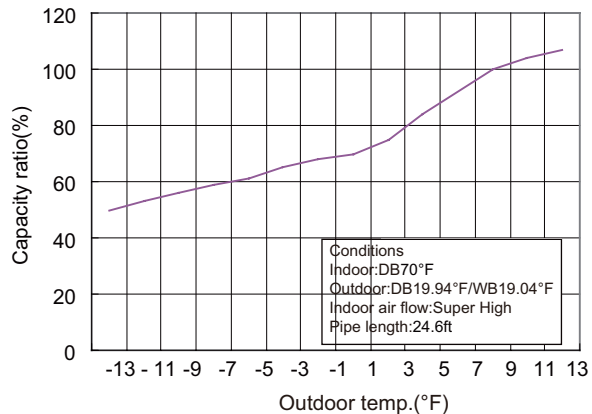

## 2.4 Cooling and Heating Data Sheet in Rated Frequency

### Cooling:

Rated cooling condition(°F) (DB/WB)		Model	Pressure of gas pipe connecting indoor and outdoor unit	Inlet and outlet pipe temperature of heat exchanger		Fan speed of indoor unit	Fan speed of outdoor unit	Compressor revolution (rps)
Indoor	Outdoor			T1 (°F)	T2 (°F)			
80/66.9	95/-	09K	130~142	in:46.4~51.8 out:51.8~57.2	in:167~181.4 out:98.6~118.4	Super High	High	52
80/66.9	95/-	12K	130~142	in:46.4~51.8 out:51.8~57.2	in:167~181.4 out:98.6~118.4	Super High	High	72

### Heating:

Rated heating condition(°F) (DB/WB)		Model	Pressure of gas pipe connecting indoor and outdoor unit	Inlet and outlet pipe temperature of heat exchanger		Fan speed of indoor unit	Fan speed of outdoor unit	Compressor revolution (rps)
Indoor	Outdoor			T1 (°F)	T2 (°F)			
70/60	19.94/19.04	09K	362~406	in:167~181.4 out:98.6~113	in:33.8~37.4 out:35.6~42.8	Super High	High	65
70/60	19.94/19.04	12K	362~406	in:167~181.4 out:98.6~113	in:33.8~37.4 out:35.6~42.8	Super High	High	77

### Instruction:

T1: Inlet and outlet pipe temperature of evaporator

T2: Inlet and outlet pipe temperature of condenser

P: Pressure at the side of big valve

Connection pipe length: 24.6ft.

## 2.5 Noise Curve

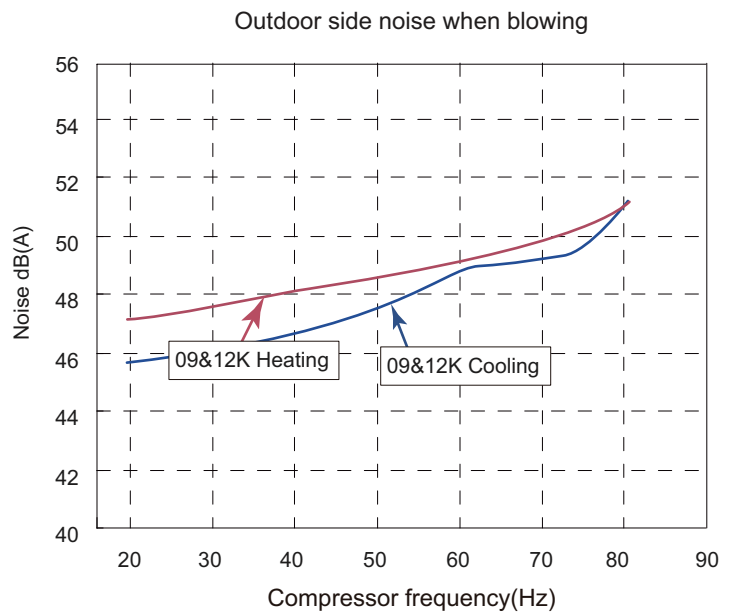
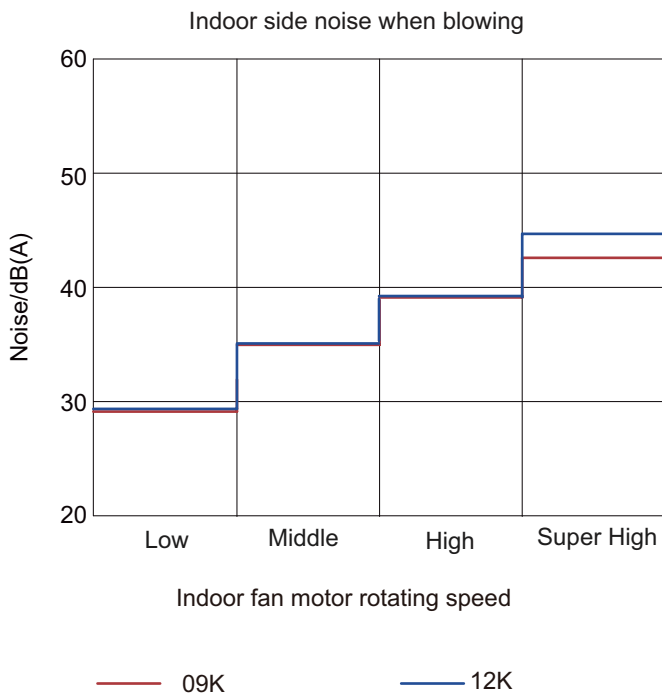

### 3. Outline Dimension Diagram

#### 3.1 Indoor Unit

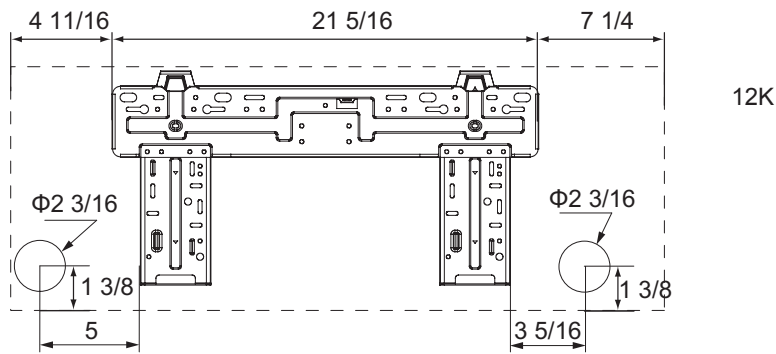
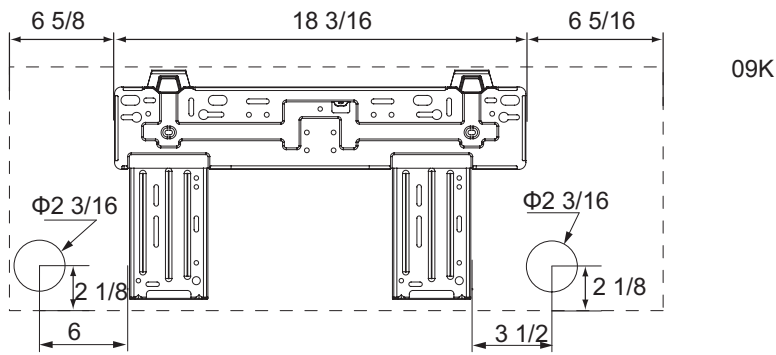
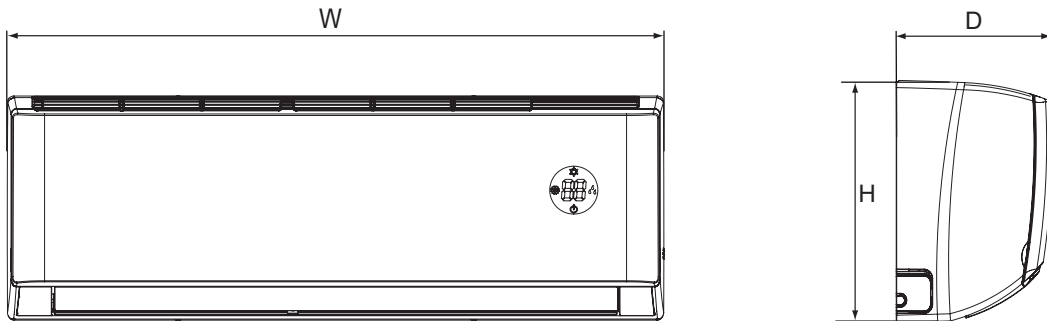

Unit:inch

MODEL	W	H	D
09K	31 1/8	10 7/8	7 7/8
12K	33 1/4	11 3/8	8 1/4

### 3.2 Outdoor Unit

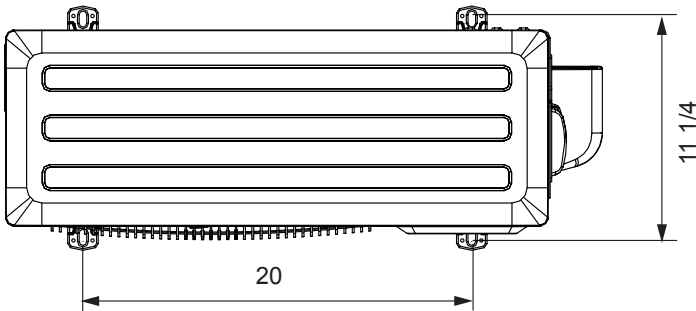
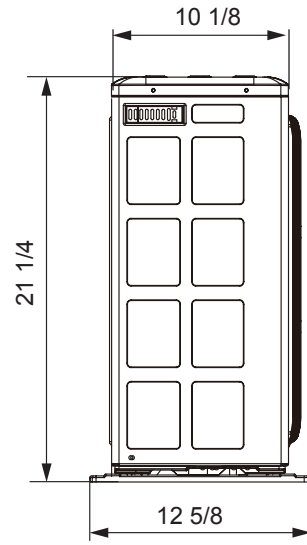
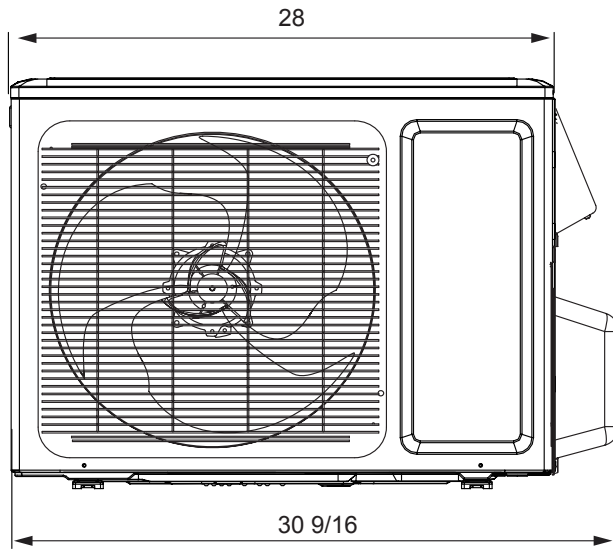

Unit:inch

# 4. Refrigerant System Diagram

Cooling and heating unit

TW12HQ3C2D(WIFI) TW09HQ3C2D(WIFI)

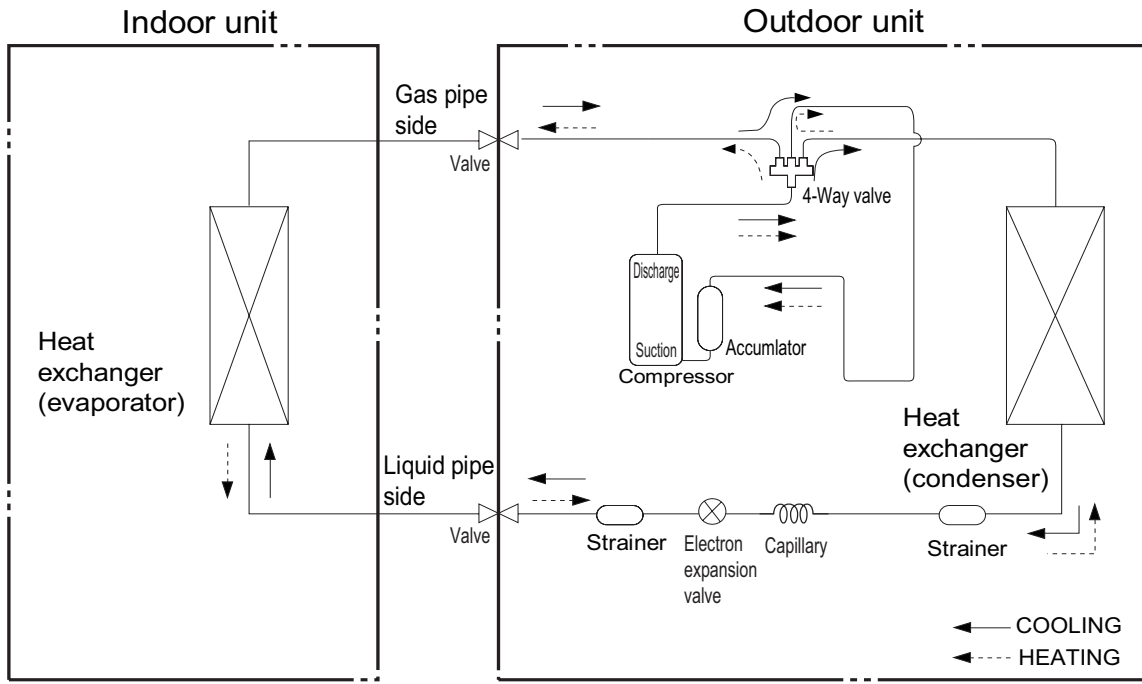

Connection pipe specification:  
 Liquid pipe: 1/4"  
 Gas pipe: 3/8"

## 5. Electrical Part

### 5.1 Wiring Diagram

• Instruction

Symbol	Symbol Color	Symbol	Symbol Color	Symbol	Name
WH	White	GN	Green	CAP	Jumper cap
YE	Yellow	BN	Brown	COMP	Compressor
RD	Red	BU	Blue		Grounding wire
YEGN	Yellow/Green	BK	Black	/	/
VT	Violet	OG	Orange	/	/

Note: Jumper cap is used to determine fan speed and the swing angle of horizontal lover for this model.

• Indoor Unit

TW09HQ3C2DI TW12HQ3C2DI

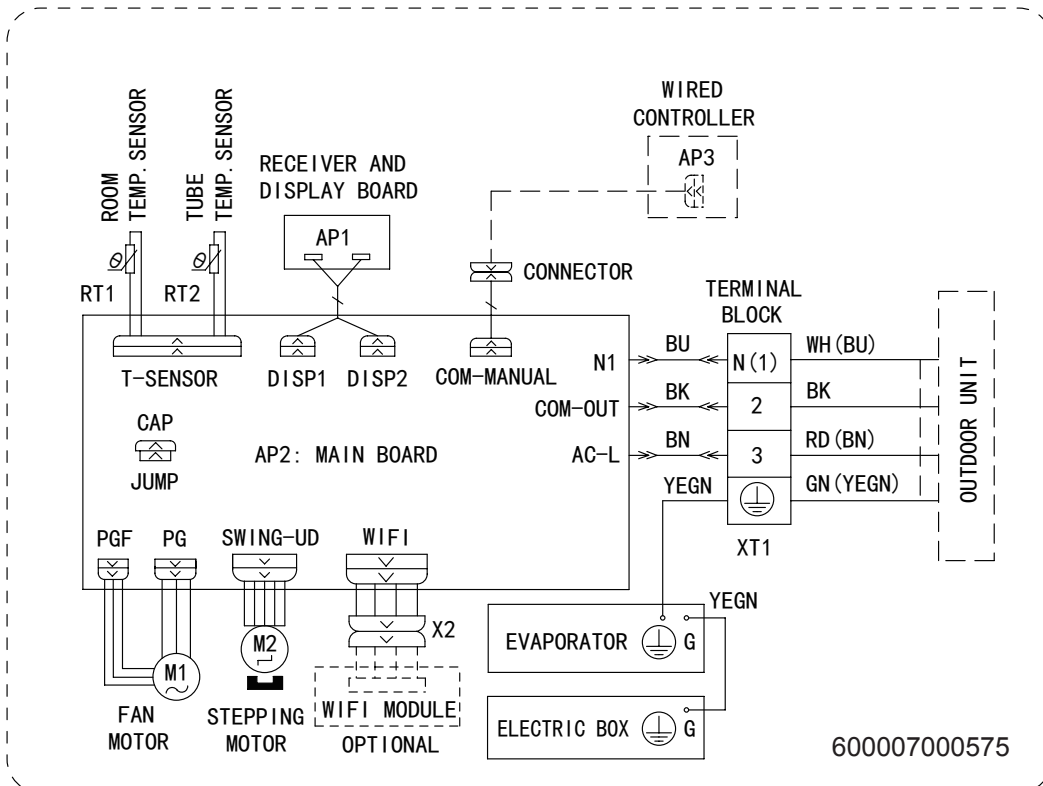



• Outdoor Unit

TW12HQ3C2DO TW09HQ3C2DO

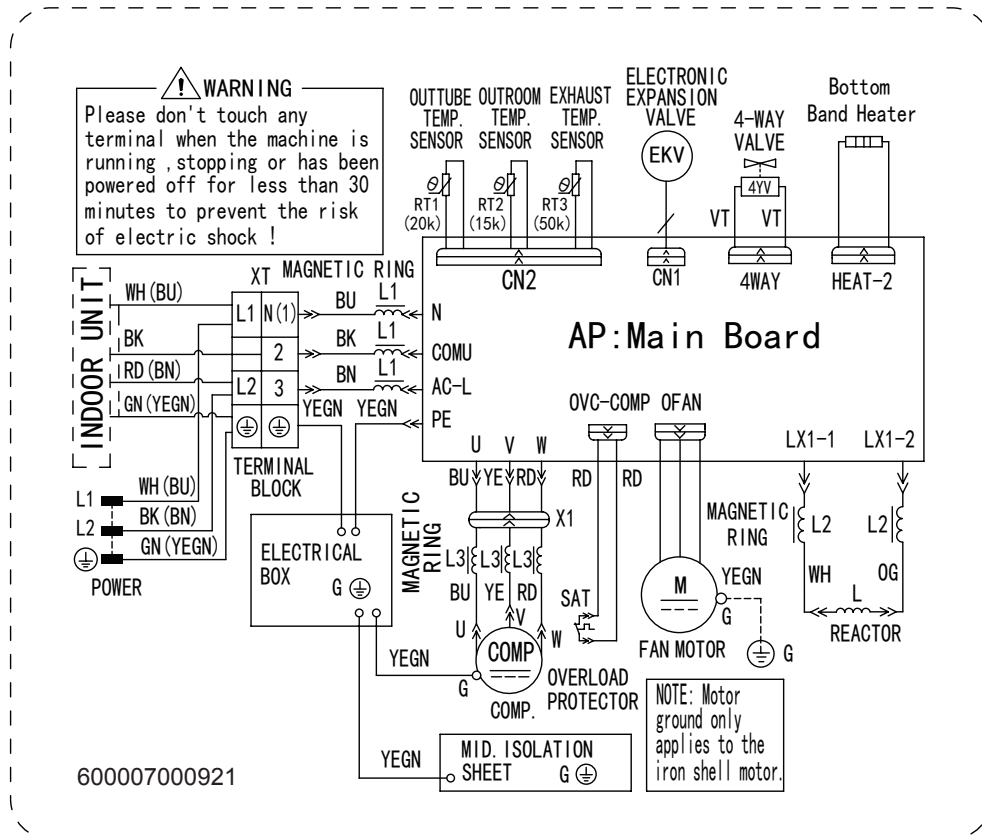

## 5.2 PCB Printed Diagram

### Indoor Unit

• Top view

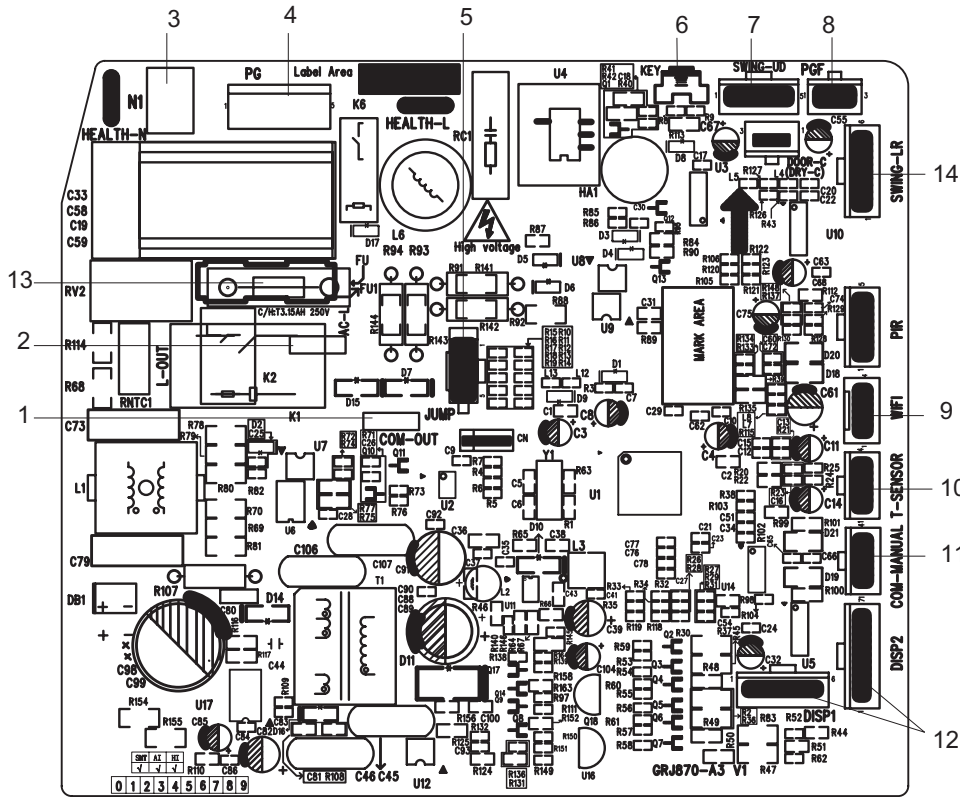

No	Name
1	Interface of communication wire for indoor unit and outdoor unit
2	Interface of live wire
3	Interface of neutral wire
4	Interface of fan
5	Jumper cap
6	Auto button
7	Up&down swing interface
8	Feedback interface of indoor unit
9	Interface of wifi
10	Interface of tube temperature sensor
11	Wired controller
12	Display interface
13	Fuse
14	Left&right swing interface

• Bottom view

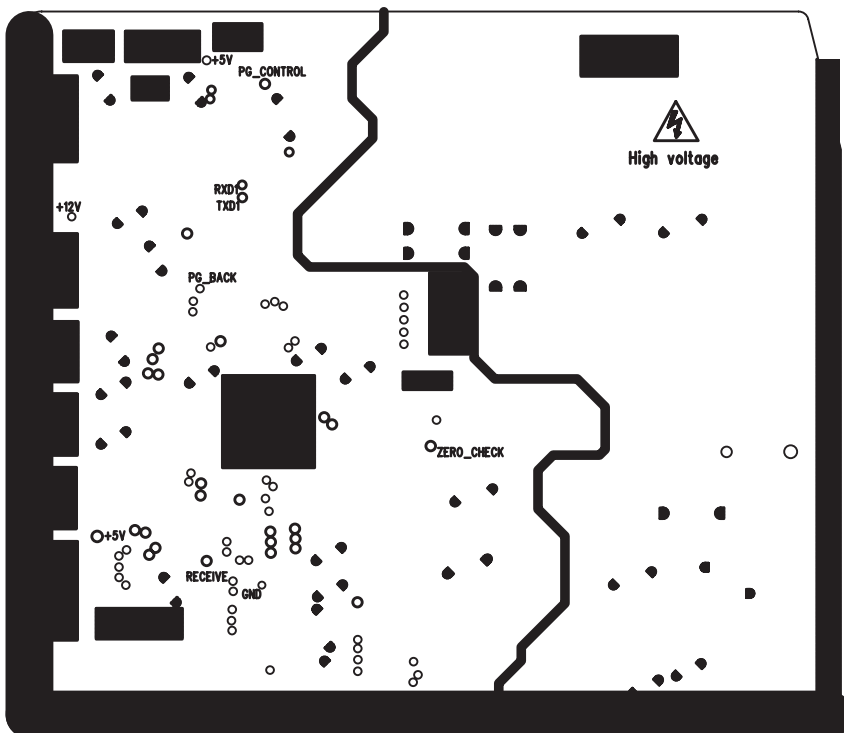

Outdoor Unit

TW09HQ3C2DO TW12HQ3C2DO

• Top view

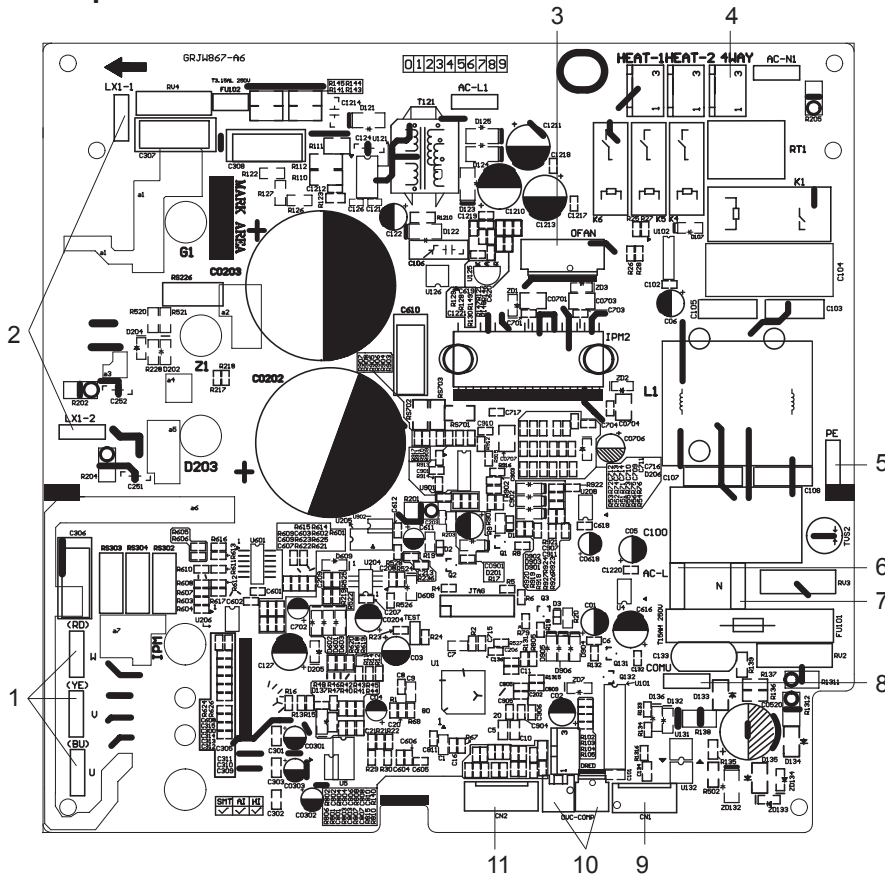

1	Compressor UVW three phase input interface
2	Interface of reactor
3	Interface of fan
4	4-way valve
5	Interface of earthing wire
6	Interface of live wire
7	Interface of neutral wire
8	Interface of communication
9	Interface of electronic expansion valve
10	Overload interface of compressor
11	Interface of temperature sensor

• Bottom view

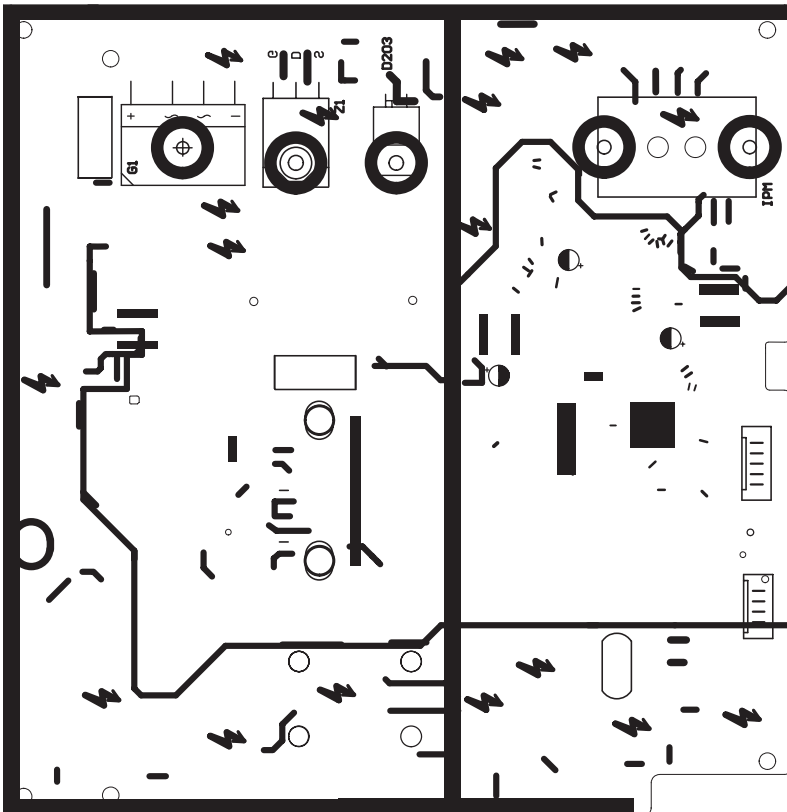

## 6. Function and Control

### 6.1 Remote Controller Introduction



#### Introduction for icons on display screen

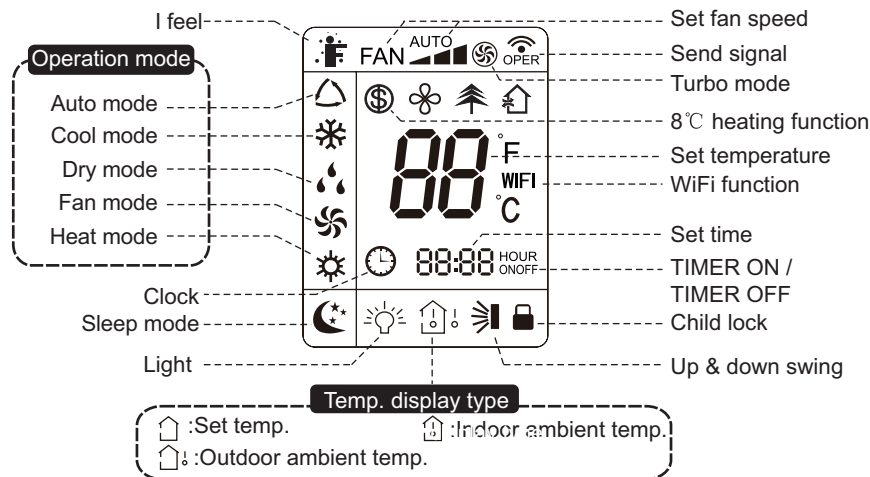

#### Introduction for buttons on remote controller

**Note:**

- This is a general use remote controller, it could be used for the air conditioners with multifunction; For some function, which the model doesn't have, if press the corresponding button on the remote controller that the unit will keep the original running status.
- After putting through the power, the air conditioner will give out a sound. Operation indicator "⏻" is ON (red indicator, the colour is different for different models). After that, you can operate the air conditioner by using remote controller.
- Under on status, pressing the button on the remote controller, the signal icon "📶" on the display of remote controller will blink once and the air conditioner will give out a "de" sound, which means the signal has been sent to the air conditioner.
- Under off status, set temperature and clock icon will be displayed on the display of remote controller (If timer on, timer off and light functions are set, the corresponding icons will be displayed on the display of remote controller at the same time); Under on status, the display will show the corresponding set function icons.

### 1. ON/OFF button

Press this button to turn on the unit. Press this button again to turn off the unit.

### 2. MODE button

Press this button to select your required operation mode.



- When selecting auto mode, air conditioner will operate automatically according to ex-factory setting. Set temperature cant be adjusted and will not be displayed as well. Press "FAN" button can adjust fan speed. Press "SWING" button can adjust fan blowing angle.
- After selecting cool mode, air conditioner will operate under cool mode. Cool indicator on indoor unit is ON(This indicator is not available for some models). Press "▲" or "▼" button to adjust set temperature. Press "FAN" button to adjust fan speed. Press "SWING" button to adjust fan blowing angle.
- When selecting dry mode, the air conditioner operates at low speed under dry mode. Dry indicator on indoor unit is ON(This indicator is not available for some models). Under dry mode, fan speed cant be adjusted. Press "SWING" button to adjust fan blowing angle.
- When selecting fan mode, the air conditioner will only blow fan, no cooling and no heating. All indicators are OFF. Press "FAN" button to adjust fan speed. Press "SWING" button to adjust fan blowing angle.
- When selecting heating mode, the air conditioner operates under heat mode. Heat indicator on indoor unit is ON(This indicator is not available for some models). Press "▲" or "▼" button to adjust set temperature. Press "FAN" button to adjust fan speed. Press "SWING" button to adjust fan blowing angle. (Cooling only unit wont receive heating mode signal. If setting heat mode with remote controller, press ON/OFF button cant start up the unit).

**Note:**

- For preventing cold air, after starting up heating mode, indoor unit will delay 1~5 minutes to blow air (actual delay time is depend on indoor ambient temperature).
- Set temperature range from remote controller: 16~30℃ ; Fan speed: auto, low speed, medium speed, high speed.

### 3. FAN button

Pressing this button can set fan speed circularly as: auto (AUTO), low(▲), medium(▲▲), high(▲▲▲).

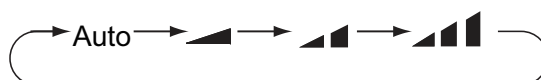

**Note:**

- Under AUTO speed, air conditioner will select proper fan speed automatically according to ex-factory setting.
- Fan speed under dry mode is low speed.
- X-FAN function: Hold fan speed button for 2s in COOL or DRY mode, the icon "⊗" is displayed and the indoor fan will continue operation for a few minutes in order to dry the indoor unit even though you have turned off the unit. After energization, X-FAN OFF is defaulted. X-FAN is not available in AUTO, FAN or HEAT mode.

This function indicates that moisture on evaporator of indoor unit will be blown after the unit is stopped to avoid mould.

- Having set X-FAN function on: After turning off the unit by pressing ON/OFF button indoor fan will continue running for a few minutes. at low speed. In this period, Hold fan speed button for 2s to stop indoor fan directly.
- Having set X-FAN function off: After turning off the unit by pressing ON/OFF button, the complete unit will be off directly.

### 4. SWING button

Press this button can select up&down swing angle. Fan blow angle can be selected circularly as below:

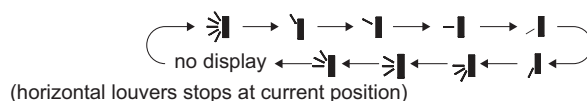

- When selecting "⤴", air conditioner is blowing fan automatically. Horizontal louver will automatically swing up & down at maximum angle.
- When selecting "⤴", "⤵", "⤶", "⤷", "⤸", air conditioner is blowing fan at fixed position. Horizontal louver will stop at the fixed position.
- When selecting "⤴", "⤵", "⤶", "⤷", "⤸", air conditioner is blowing fan at fixed angle. Horizontal louver will send air at the fixed angle.
- Hold "⤴" button above 2s to set your required swing angle. When reaching your required angle, release the button.

**Note:**

- "⤴", "⤵", "⤶" may not be available. When air conditioner receives this signal, the air conditioner will blow fan automatically.

### 5. TURBO button

Under COOL or HEAT mode, press this button to turn to quick COOL or quick HEAT mode. "⊗" icon is displayed on remote controller. Press this button again to exit turbo function and "⊗" icon will disappear.

## 6. ▲/▼ button

- Press "▲" or "▼" button once increase or decrease set temperature 1°C(1°F). . Holding "▲" or "▼" button, 2s later, set temperature on remote controller will change quickly. On releasing button after setting is finished, temperature indicator on indoor unit will change accordingly. (Temperature can't be adjusted under auto mode)
- When setting TIMER ON, TIMER OFF or CLOCK, press "▲" or "▼" button to adjust time. (Refer to CLOCK, TIMER ON, TIMER OFF buttons)

## 7. SLEEP button

Under COOL, HEAT mode, press this button to start up sleep function. "☾" icon is displayed on remote controller. Press this button again to cancel sleep function and "☾" icon will disappear.

## 8. TEMP button

By pressing this button, you can see indoor set temperature, indoor ambient temperature or outdoor ambient temperature on indoor units display. The setting on remote controller is selected circularly as below:

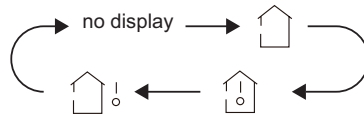

- When selecting "☰" or no display with remote controller, temperature indicator on indoor unit displays set temperature.
- When selecting "☷" with remote controller, temperature indicator on indoor unit displays indoor ambient temperature.
- When selecting "☶" with remote controller, temperature indicator on indoor unit displays outdoor ambient temperature.

### Note:

- Outdoor temperature display is not available for some models. At that time, indoor unit receives "☶" signal, while it displays indoor set temperature.
- Its defaulted to display set temperature when turning on the unit. There is no display in the remote controller.
- Only for the models whose indoor unit has dual-8 display.
- When selecting displaying of indoor or outdoor ambient temperature, indoor temperature indicator displays corresponding temperature and automatically turn to display set temperature after three or five seconds.

## 9. WIFI button

When WiFi function is turned on, "WiFi" icon will be displayed on the remote controller; when WiFi function is turned off, "WiFi" icon will disappear. How to turn on WiFi: Press "WiFi" button to turn on WiFi function.

How to turn off WiFi: Hold "WiFi" button for 5s to turn off WiFi function.

Under off status, press "MODE" and "WiFi" buttons simultaneously for 1s, WiFi module will restore factory settings.

- This function is only available for some models.

## 10. LIGHT button

Press this button to turn off display light on indoor unit. "☀" icon on remote controller disappears. Press this button again to turn on display light. "☀" icon is displayed.

## 11. CLOCK button

Press this button to set clock time. "🕒" icon on remote controller will blink. Press "▲" or "▼" button within 5s to set clock time. Each pressing of "▲" or "▼" button, clock time will increase or decrease 1 minute. If hold "▲" or "▼" button, 2s later, time will change quickly. Release this button when reaching your required time. Press "CLOCK" button to confirm the time. "🕒" icon stops blinking.

### Note:

- Clock time adopts 24-hour mode.
- The interval between two operation cant exceeds 5s. Otherwise, remote controller will quit setting status. Operation for TIMER ON/TIMER OFF is the same.

## 12. TIMER ON / TIMER OFF button

### TIMER ON button

"TIMER ON" button can set the time for timer on. After pressing this button, "🕒" icon disappears and the word "ON" on remote controller blinks. Press "▲" or "▼" button to adjust TIMER ON setting. After each pressing "▲" or "▼" button, TIMER ON setting will increase or decrease 1min. Hold "▲" or "▼" button, 2s later, the time will change quickly until reaching your required time. Press "TIMER ON" to confirm it. The word "ON" will stop blinking. "🕒" icon resumes displaying. Cancel TIMER ON: Under the condition that TIMER ON is started up, press "TIMER ON" button to cancel it.

### TIMER OFF button

"TIMER OFF" button can set the time for timer off. After pressing this button, "🕒" icon disappears and the word "OFF" on remote controller blinks. Press "▲" or "▼" button to adjust TIMER OFF setting. After each pressing "▲" or "▼" button, TIMER OFF setting will increase or decrease 1min. Hold "▲" or "▼" button, 2s later, the time will change quickly until reaching your required time. Press "TIMER OFF" word "OFF" will stop blinking. "🕒" icon resumes displaying. Cancel TIMER OFF. Under the condition that TIMER OFF is started up, press "TIMER OFF" button to cancel it.

**Note:**

- Under on and off status, you can set TIMER OFF or TIMER ON simultaneously.
- Before setting TIMER ON or TIMER OFF, please adjust the clock time.
- After starting up TIMER ON or TIMER OFF, set the constant circulating valid. After that, air conditioner will be turned on or turned off according to setting time. ON/OFF button has no effect on setting. If you don't need this function, please use remote controller to cancel it.

If "H1" is displayed on the remote controller while it's not operated by the professional person/after-sales person, it belongs to the misoperation. Please operate it as below to cancel it. Under the OFF status of remote controller, hold the Mode button for 5s to cancel "H1" display.

**Note:**

- If remote controller displays "H1", it belongs to the normal function reminder. If the unit is defrosting under heating mode, it operates according to H1 defrosting mode. "H1" won't be displayed on the panel of indoor unit;
- Once you set H1 mode, if you turn off unit by remote controller, H1 will display 3 times on the remote controller and then disappear;
- Also, when you set H1 mode, when you change to heating mode, H1 will display 3 times on the remote controller and then disappear.

**Function introduction for combination buttons****1. Energy-saving function**

Under cooling mode, press "TEMP" and "CLOCK" buttons simultaneously to start up or turn off energy-saving function. When energy-saving function is started up, "SE" will be shown on remote controller, and air conditioner will adjust the set temperature automatically according to ex-factory setting to reach to the best energy-saving effect. Press "TEMP" and "CLOCK" buttons simultaneously again to exit energy-saving function.

**Note:**

- Under energy-saving function, fan speed is defaulted at auto speed and it can't be adjusted.
- Under energy-saving function, set temperature can't be adjusted. Press "TURBO" button and the remote controller won't send signal.
- Sleep function and energy-saving function can't operate at the same time. If energy-saving function has been set under cooling mode, press sleep button will cancel energy-saving function. If sleep function has been set under cooling mode, start up the energy-saving function will cancel sleep function.

**2. 8 °C heating function**

Under heating mode, press "TEMP" and "CLOCK" buttons simultaneously to start up or turn off 8 °C heating function. When this function is started up, "8°C" and "8°C" will be shown on remote controller, and the air conditioner keep the heating status at 8 °C. Press "TEMP" and "CLOCK" buttons simultaneously again to exit 8 °C heating function.

**Note:**

- Under 8 °C heating function, fan speed is defaulted at auto speed and it can't be adjusted.
- Under 8 °C heating function, set temperature can't be adjusted. Press "TURBO" button and the remote controller won't send signal.
- Sleep function and 8 °C heating function can't operate at the same time. If 8 °C heating function has been set under cooling mode, press sleep button will cancel 8 °C heating function. If sleep function has been set under cooling mode, start up the 8 °C heating function will cancel sleep function.
- Under °F temperature display, the remote controller will display 46 °F heating.

**3. Child lock function**

Press "▲" and "▼" simultaneously to turn on or turn off child lock function. When child lock function is on, "🔒" icon is displayed on remote controller. If you operate the remote controller, the "🔒" icon will blink three times without sending signal to the unit.

**4. Temperature display switchover function**

Under OFF status, press "▼" and "MODE" buttons simultaneously to switch temperature display between °C and °F.

**5. I FEEL Function**

Press "▲" and "MODE" buttons simultaneously to start I FEEL function and "🌡️" will be displayed on the remote controller. After this function is set, the remote controller will send the detected ambient temperature to the controller and the unit will automatically adjust the indoor temperature according to the detected temperature. Press these two buttons simultaneously again to close I FEEL function and "🌡️" will disappear.

- Please put the remote controller near user when this function is set. Do not put the remote controller near the object of high temperature or low temperature in order to avoid detecting inaccurate ambient temperature. When I FEEL function is turned on, the remote controller should be put within the area where indoor unit can receive the signal sent by the remote controller.

## Replacement of batteries in remote controller

1. Press the back side of remote controller marked with "  ", as shown in the fig, and then push out the cover of battery box along the arrow direction.
2. Replace two 7# (AAA 1.5V) dry batteries, and make sure the position of "+" polar and "-" polar are correct.
3. Reinstall the cover of battery box.

### Note:

- During operation, point the remote control signal sender at the receiving window on indoor unit.
- The distance between signal sender and receiving window should be no more than 8m, and there should be no obstacles between them.
- Signal may be interfered easily in the room where there is fluorescent lamp or wireless telephone; remote controller should be close to indoor unit during operation.
- Replace new batteries of the same model when replacement is required.
- When you dont use remote controller for a long time, please take out the batteries.
- If the display on remote controller is fuzzy or theres no display, please replace batteries.

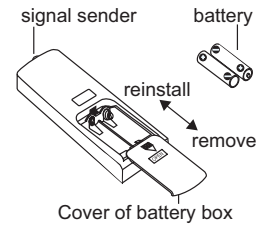



## 6.2 Ewpe Smart App Operation Manual

### Control Flow Chart

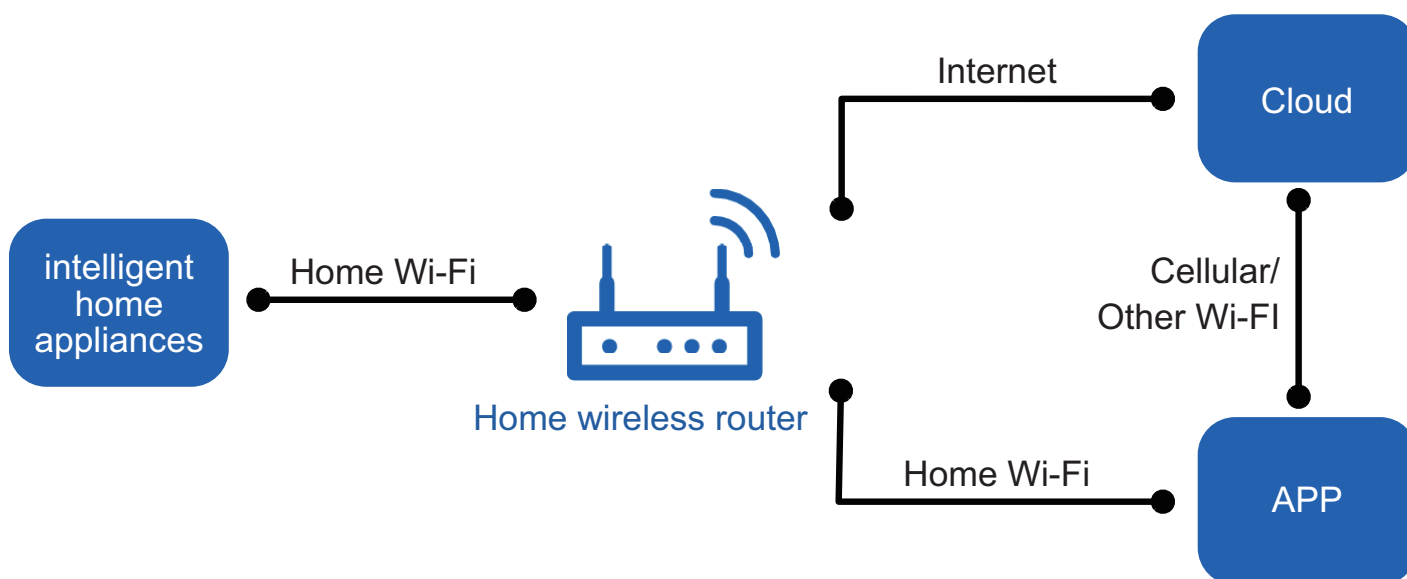

### Operating Systems

Requirement for User's smart phone:



iOS system  
Support iOS7.0 and  
above version



Android system  
Support Android 4.4 and  
above version

### Download and installation



App Download Linkage

Scan the QR code or search "Ewpe Smart" in the application market to download and install it. When "Ewpe Smart" App is installed, register the account and add the device to achieve long-distance control and LAN control of smart home appliances. For more information, please refer to "Help" in App.

## 6.3 Brief Description of Modes and Functions

### ● Indoor Unit

#### 1. Basic function of system

##### (1) Cooling mode

- (1) Under this mode, fan and swing operates at setting status. Temperature setting range is 60.8~86.0°F.
- (2) During malfunction of outdoor unit or the unit is stopped because of protection, indoor unit keeps original operation status.

##### (2) Drying mode

- (1) Under this mode, fan operates at low speed and swing operates at setting status. Temperature setting range is 60.8~86.0°F.
- (2) During malfunction of outdoor unit or the unit is stopped because of protection, indoor unit keeps original operation status.
- (3) Protection status is same as that under cooling mode.
- (4) Sleep function is not available for drying mode.

##### (3) Heating mode

- (1) Under this mode, Temperature setting range is 60.8~86.0°F.
- (2) Working condition and process for heating mode:

When turn on the unit under heating mode, indoor unit enters into cold air prevention status. When the unit is stopped or at OFF status, and indoor unit has been started up just now, the unit enters into residual heat-blowing status.

##### (4) Working method for AUTO mode:

1. Working condition and process for AUTO mode:
  - a. Under AUTO mode, standard heating  $T_{\text{preset}}=68.0^{\circ}\text{F}$  and standard cooling  $T_{\text{preset}}=77.0^{\circ}\text{F}$ . The unit will switch mode automatically according to ambient temperature.
  2. Protection function
    - a. During cooling operation, protection function is same as that under cooling mode.
    - b. During heating operation, protection function is same as that under heating mode.
  3. Display: Set temperature is the set value under each condition. Ambient temperature is ( $T_{\text{amb.}}-T_{\text{compensation}}$ ) for heat pump unit and  $T_{\text{amb.}}$  for cooling only unit.
  4. If theres I feel function,  $T_{\text{compensation}}$  is 0. Others are same as above.

##### (5) Fan mode

Under this mode, indoor fan operates at set fan speed. Compressor, outdoor fan, 4-way valve and electric heating tube stop operation. Indoor fan can select to operate at high, medium, low or auto fan speed. Temperature setting range is 60.8~86.0°F.

#### 2. Other control

##### (1) Buzzer

Upon energization or availably operating the unit or remote controller, the buzzer will give out a beep.

##### (2) Auto button

If press this auto button when turning off the unit, the complete unit will operate at auto mode. Indoor fan operates at auto fan speed and swing function is turned on. Press this auto button at ON status to turn off the unit.

##### (3) Auto fan

Heating mode: During auto heating mode or normal heating ode, auto fan speed will adjust the fan speed automatically according to ambient temperature and set temperature.

##### (4) Sleep

After setting sleep function for a period of time, system will adjust set temperature automatically.

##### (5) Timer function:

General timer and clock timer functions are compatible by equipping remote controller with different functions.

##### (6) Memory function

memorize compensation temperature, off-peak energization value.

Memory content: mode, up&down swing, light, set temperature, set fan speed, general timer (clock timer cant be memorized).

After power recovery, the unit will be turned on automatically according to memory content.

##### (7) Health function

During operation of indoor fan, set health function by remote controller. Turn off the unit will also turn off health function.

Turn on the unit by pressing auto button, and the health is defaulted ON.

**(8) I feel control mode**

After controller received I feel control signal and ambient temperature sent by remote controller, controller will work according to the ambient temperature sent by remote controller.

**(9) Compulsory defrosting function**

(1) Start up compulsory defrosting function

Under ON status, set heating mode with remote controller and adjust the temperature to 60.8°F. Press “+, -, +, -, +,-” button successively within 5s and the complete unit will enter into compulsory defrosting status. Meanwhile, heating indicator on indoor unit will ON 10s and OFF 0.5s successively. (Note: If complete unit has malfunction or stops operation due to protection, compulsory defrosting function can be started up after malfunction or protection is resumed.)

(2) Exit compulsory defrosting mode

After compulsory defrosting is started up, the complete unit will exit defrosting operation according to the actual defrosting result, and the complete unit will resume normal heating operation.

**(10) Refrigerant recovery function:**

(1) Enter refrigerant recycling function

Within 5min after energizing (unit ON or OFF status is ok), continuously press LIGHT button for 3 times within 3s to enter refrigerant recycling mode; Fo is displayed and refrigerant recycling function is started. At this moment, the maintenance people closes liquid valve. After 5min, stick the thimble of maintenance valve with a tool. If there is no refrigerant spraying out, close the gas valve immediately and then turn off the unit to remove the connection pipe.

(2) Exit refrigerant recycling function

After entering refrigerant recycling mode, when receive any remote control signal or enter refrigerant recycling mode for 25min, the unit will exit refrigerant recycling mode automatically. If the unit is in standby mode before refrigerant recycling, it will be still in standby mode after finishing refrigerant recycling; if the unit is in ON status before refrigerant recycling, it will still run in original operation mode.

**(11) Ambient temperature display control mode**

1. When user set the remote controller to display set temperature (corresponding remote control code: 01), current set temperature will be displayed.

2. Only when remote control signal is switched to indoor ambient temperature display status (corresponding remote control code: 10) from other display status (corresponding remote control code: 00, 01, 11), controller will display indoor ambient temperature for 3s and then turn back to display set temperature.

Under this mode, indoor fan operates at set fan speed. Compressor, outdoor fan, 4-way valve and electric heating tube stop operation. Indoor fan can select to operate at high, medium, low or auto fan speed. Temperature setting range is 60.8~86.0°F.

**(12) Off-peak energization function:**

Adjust compressors minimum stop time. The original minimum stop time is 180s and then we change to:

The time interval between two start-ups of compressor can't be less than  $180+T$  s ( $0 \leq T \leq 15$ ). T is the variable of controller. That's to say the minimum stop time of compressor is 180s~195s. Read-in T into memory chip when refurbish the memory chip each time. After power recovery, compressor can only be started up after  $180+T$  s at least.

**(13) SE control mode**

The unit operates at SE status.

**(14) X-fan mode**

When X-fan function is turned on, after turn off the unit, indoor fan will still operate at low speed for 2min and then the complete unit will be turned off. When x-fan function is turned off, after turn off the unit, the complete unit will be turned off directly.

**(15) 8° heating function**

Under heating mode, you can set 8° heating function by remote controller. The system will operate at 8° set temperature.

**(16) Turbo fan control function**

Set turbo function under cooling or heating mode to enter into turbo fan speed. Press fan speed button to cancel turbo wind.

No turbo function under auto, dry or fan mode.

## Outdoor Units

### 1. Input Parameter Compensation and Calibration

#### (1) Check the ambient temperature compensation function Indoor ambient temperature compensation function.

a. In cooling mode, the indoor ambient temperature participating in computing control = ( $T_{\text{indoor ambient temperature}} - \Delta T_{\text{cooling indoor ambient temperature compensation}}$ )

b. In heating mode, the indoor ambient temperature participating in computing control = ( $T_{\text{indoor ambient temperature}} - \Delta T_{\text{heating indoor ambient temperature compensation}}$ )

#### (2) Check effective judgment controls of parameters

Effective judgment function of the outdoor exhaust temperature thermo-bulb When conditions a and b are satisfied, the outdoor exhaust temperature thermo-bulb is judged not to be connected into place, the mainboard of outer units will display failure of the outdoor exhaust temperature thermo-bulb (not connected into place), stop the machine for repairing, and resume the machine by remote controls of ON/OFF.

a. Judgment of exhaust detection temperature change:

After the compressor starts up and runs for 10 minutes, if the compressor frequency  $f \geq 40\text{Hz}$ , and the rising value  $T_{\text{exhaust}}$  ( $T_{\text{exhaust (after start-up for 10 minutes)}} - T_{\text{exhaust (before start-up)}}$ )  $< 35.6^\circ\text{F}$ , the outdoor exhaust temperature thermo-bulb can be judged not to be connected into place (judging once when the power is on the first time).

b. Comparative judgment of exhaust detection temperature and condenser detection temperature ( $T_{\text{pipe temperature}} = T_{\text{outdoor pipe temperature in cooling mode}}$ ,  $T_{\text{pipe temperature}} = T_{\text{indoor pipe temperature in heating mode}}$ ): After the compressor starts up and runs for 10 minutes, if the compressor frequency  $f \geq 40\text{Hz}$ , and  $T_{\text{pipe temperature}} \geq (T_{\text{exhaust}} + 37.4)$ , the outdoor exhaust temperature thermobulb can be judged not to be connected into place (judging once when power is on the first time).

### 2. Basic Functions

#### (1) Cooling Mode

##### 1. Conditions and processes of cooling operation:

(1) If the compressor is shut down, and  $[T_{\text{setup}} - (T_{\text{indoor ambient temperature}} - \Delta T_{\text{cooling indoor ambient temperature compensation}})] \leq 32.9^\circ\text{F}$ , start up the machine for cooling, the cooling operation will start;

(2) During operations of cooling, if  $32^\circ\text{F} \leq [T_{\text{setup}} - (T_{\text{indoor ambient temperature}} - \Delta T_{\text{cooling indoor ambient temperature compensation}})] < 35.6^\circ\text{F}$ , the cooling operation will be still running;

(3) During operations of cooling, if  $35.6^\circ\text{F} \leq [T_{\text{setup}} - (T_{\text{indoor ambient temperature}} - \Delta T_{\text{cooling indoor ambient temperature compensation}})]$ , the cooling operation will stop after reaching the temperature point.

##### 2. Temperature setting range

(1) If  $T_{\text{outdoor ambient temperature}} \geq [T_{\text{low-temperature cooling temperature}}]$ , the temperature can be set at:  $60.8\sim 86^\circ\text{F}$  (Cooling at room temperature);

(2) If  $T_{\text{outdoor ambient temperature}} < [T_{\text{low-temperature cooling temperature}}]$ , the temperature can be set at:  $77\sim 86^\circ\text{F}$  (Cooling at low temperature), that is, the minimum setting temperature for outer units judgment is  $77^\circ\text{F}$ .

#### (2) Dehumidifying Mode

1. Conditions and processes of dehumidifying operations: Same as the cooling mode;

2. The temperature setting range is:  $60.8\sim 86^\circ\text{F}$ ;

#### (3) Air-supplying Mode

1. The compressor, outdoor fans and four-way valves are switched off;

2. The temperature setting range is:  $60.8\sim 86^\circ\text{F}$ .

#### (4) Heating Mode

1. Conditions and processes of heating operations: ( $T_{\text{indoor ambient temperature}}$  is the actual detection temperature of indoor environment thermo-bulb,  $T_{\text{heating indoor ambient temperature compensation}}$  is the indoor ambient temperature compensation during heating operations)

(1) If the compressor is shut down, and  $[(T_{\text{indoor ambient temperature}} - \Delta T_{\text{heating indoor ambient temperature compensation}}) - T_{\text{setup}}] \leq 32.9^\circ\text{F}$ , start the machine to enter into heating operations for heating;

(2) During operations of heating, if  $32^\circ\text{F} \leq [(T_{\text{indoor ambient temperature}} - \Delta T_{\text{heating indoor ambient temperature compensation}}) - T_{\text{setup}}] < 35.6^\circ\text{F}$ , the heating operation will be still running;

(3) During operations of heating, if  $35.6^\circ\text{F} \leq [(T_{\text{indoor ambient temperature}} - \Delta T_{\text{heating indoor ambient temperature compensation}}) - T_{\text{setup}}]$ , the heating operation will stop after reaching the temperature point.

2. The temperature setting range in this mode is:  $60.8\sim 86^\circ\text{F}$ .

### 3. Special Functions

#### Defrosting Control

##### ① Conditions for starting defrosting

After the time for defrosting is judged to be satisfied, if the temperature for defrosting is satisfied after detections for continuous 3minutes, the defrosting operation will start.

##### ② Conditions of finishing defrosting

The defrosting operation can exit when any of the conditions below is satisfied:

##### ③ $T_{\text{outdoor pipe temperature}} \geq (T_{\text{outdoor ambient temperature}} - [T_{\text{temperature 1 of finishing defrosting}}])$ ;

##### ④ The continuous running time of defrosting reaches [tmax. defrosting time].

### 4. Control Logic

#### (1) Compressor Control

Start the compressor after starting cooling, heating, dehumidifying operations, and the outer fans start for 5s; When the machine is shutdown, in safety stops and when switching to air-supplying mode, the compressor will stop immediately. In all modes: once the compressor starts up, it will not be allowed to stop until having run for the [tmin. compressor running time] (Note: including cases of shutdown when the temperature point is reached; except the cases requiring stopping the compressor such as fault protection, remote shutdown, mode switching etc.); In all modes: once the compressor stops, it will be allowed be restart after 3-minute delay (Note: The indoor units have a function of power memory, the machine can be restarted after remote shutdown and powering up again without delay).

##### 1. Cooling mode

Start the machine to enter into cooling operation for cooling, the compressor is switched on.

##### 2. Dehumidifying mode

Same as the cooling mode.

##### 3. Air-supplying mode

The compressor is switched off.

##### 4. Heating mode

(1) Start the machine to enter into heating operation for heating, the compressor is switched on.

(2) Defrosting:

a. Defrosting starts: the compressor is shut down, and restarts it after 55-second delay.

b. Defrosting ends: the compressor stops, then starts it after 55-second delay.

#### (2) Outer Fans Control

Notes:

Only the outer fans run for at least 80s in each air flow speed can the air flow be switched;

After the outer fans run compulsively in high speed for 80s when the machine starts up, control the air flow according to the logic.

After remote shutdown, safety stops, and when the machine stops after reaching the temperature point, as well as after the compressor stops, extend 1 minute, the outer fans will stop (During the period in the 1 minute, the air flow of outer fans can be changed according to the outdoor ambient temperature changes); When running with force, the outdoor fans shall run in the highest air flow.

#### (3) 4-way valve control

1. The 4-way valve control under the modes of Cooling, dehumidification and supplying air: closing;

2. The status of 4-way valve control under the heating mode: getting power;

(1) 4-way valve power control under heating mode

a. Starts the machine under heating mode, the 4-way valve will get power immediately.

(2) 4-way valve power turn-off control under heating mode

a. When you should turn off the power or switch to other mode under heating mode, the power of 4-way valve will be cut after 2 minutes of the compressor stopped.

b. When all kinds of protection stops, the power of 4-way valve will be cut after delaying 4 minutes.

(3) Defrosting control under heating mode:

a. Defrosting begins: The power of 4-way valve will be cut after 50s of entering into the defrosting compressor.

b. Defrosting stops: The 4-way valve will get power after 50s of exiting the defrosting compressor.

#### (4) Evaporator frozen-preventing protection function

At the mode of Cooling, dehumidifying:

Evaporator frozen-preventing protection function is allowed to begin after 6 min of starting the compressor.

**1. Starting estimation:**

After the compressor stopped working for 180s, if  $T_{\text{inner pipe}} > [T_{\text{frozen-preventing frequency-limited temperature}}$  (the temperature of hysteresis is 35.6°F ), the machine is only allowed to start for operating, otherwise it should not be started, and should be stopped to treat according to the frozen-preventing protection: Clear the trouble under the mode of power turn-off / heating, and the protection times are not counted.

**2. Frequency limited**

$[T_{\text{frozen-preventing normal speed frequency-reducing temperature}}] \leq [T_{\text{inner pipe}} T_{\text{frozen-preventing frequency-limited temperature}}]$  , you should limit the frequency raising of compressor.

**3. Reducing frequency at normal speed:**

If  $[T_{\text{frozen-preventing high speed frequency-reducing temperature}}] \leq [T_{\text{inner pipe}} T_{\text{frozen-preventing normal speed frequency-reducing temperature}}]$ , you should adjust the compressor frequency by reducing 8Hz/90s till the lower limit;

**4. Reducing frequency at high speed:**

If  $[T_{\text{frozen-preventing power turn-off temperature}}] \leq T_{\text{inner pipe}} [T_{\text{frozen-preventing high speed frequency-reducing temperature}}]$  you should adjust the compressor frequency by reducing 30Hz/90s till the lower limit;

**5. Power turn-off:**

If the  $T_{\text{inner pipe}} < [T_{\text{frozen-preventing power turn-off temperature}}]$ , then frozen-preventing protect to stop the machine; If  $[T_{\text{frozen-preventing frequency-limited temperature}}] < T_{\text{inner pipe}}$  , and the compressor has stopped working for 3 minutes, the whole machine should be allowed to operate.

6. If the frozen-preventing protection power turn-off continuously occurs for six times, it should not be resumed automatically, and you should press the ON/OFF button to resume if the fault keeps on. During the process of running, if the running time of compressor exceeds the t evaporator frozen-preventing protection times zero clearing time , the times of frozen-preventing power turn-off should be cleared to recount. The mode of stopping the machine or transferring to supply air will clear the trouble times immediately (if the trouble can not be resumed, mode transferring will not clear it).

**(5) Overload protection function**

Overload protection function at the mode of Cooling and dehumidifying

**1. Starting estimation:**

After the compressor stopped working for 180s, if  $T_{\text{outer pipe}} < [T_{\text{Cooling overload frequency-limited temperature}}]$  (the temperature of hysteresis is 35.6°F ), the machine is allowed to start, otherwise it should not be started, and should be stopped to treat according to the overload protection: Clear the trouble at the mode of power turn-off / heating, and the protection times are not counted.

**2. Frequency limited**

If  $[T_{\text{Cooling overload frequency-limited temperature}}] \leq [T_{\text{outer pipe}} T_{\text{Cooling overload frequency reducing temperature at normal speed}}]$ , you should limit the frequency raising of compressor.

**3. Reducing frequency at normal speed and power turn-off:**

If  $[T_{\text{Cooling overload frequency reducing temperature at high speed}}] \leq T_{\text{outer pipe}} < [T_{\text{Cooling overload power turn-off temperature}}]$  , you should adjust the compressor frequency by reducing 8Hz/90s till the lower limit; After it was running 90s at the lower limit, if  $[T_{\text{Cooling overload frequency reducing temperature at normal speed}}] \leq T_{\text{outer pipe}}$ , then Cooling overload protects machine stopping;

**4. Reducing frequency at high speed and stop machine:**

If  $[T_{\text{Cooling overload frequency reducing temperature at high speed}}] \leq T_{\text{outer pipe}} [T_{\text{Cooling overload power turn-off temperature}}]$ , you should adjust the compressor frequency by reducing 30Hz/90s till the lower limit; After it was running 90s at the lower limit, if  $[T_{\text{Cooling overload frequency reducing temperature at normal speed}}] \leq [T_{\text{outer pipe}}]$ , then Cooling overload protects machine stopping;

**5. Power turn-off:**

If the  $[T_{\text{Cooling overload power turn-off temperature}}] \leq T_{\text{outer pipe}}$ , then Cooling overload protects machine stopping; If  $[T_{\text{outer pipe}}] < [T_{\text{Cooling overload frequency-limited temperature}}]$  and the compressor has been stopped working for 3 minutes, the machine should be allowed to operate.

6. If the Cooling overload protection power turn-off continuously occurs for six times, it should not be resumed automatically, and you should press the ON/OFF button to resume if the fault keeps on. During the process of running, if the running time of compressor exceeds the t overload protection times zero clearing time , the times of overload protection power turn-off should be cleared to recount. The mode of stopping the machine or transferring to supply air will clear the trouble times immediately (if the trouble can not be resumed, transferring mode will not clear it).

**Overload protection function at the mode of heating**

**Starting estimation :**

After the compressor stopped working for 180s, if  $T_{\text{inner pipe}} T_{\text{heating overload frequency-limited temperature}}$  (the temperature of hysteresis is 35.6°F ), the machine is allowed to start, otherwise it should not be started, and should be stopped to treat according to the overload protection:

Clear the trouble at the mode of power turn-off / heating, and the protection times are not counted.



**1. Frequency limited**

If  $[T_{\text{heating overload frequency-limited temperature}}] \leq T_{\text{inner pipe}} < [T_{\text{heating overload frequency reducing temperature at normal speed}}]$  , you should limit the frequency raising of compressor.

**2. Reducing frequency at normal speed and stopping machine:**

If  $[T_{\text{heating overload frequency reducing temperature at normal speed}}] \leq T_{\text{inner pipe}} < [T_{\text{heating overload frequency reducing temperature at high speed}}]$ , you should adjust the compressor frequency by reducing 8Hz/90s till the lower limit; After it was running 90s at the lower limit, if  $T_{\text{heating overload frequency reducing temperature at normal speed}} \leq T_{\text{inner pipe}}$ , then overload protects machine stopping;

**3. Reducing frequency at high speed and power turn-off:**

If  $[T_{\text{heating overload frequency reducing temperature at high speed}}] \leq T_{\text{inner pipe}} < [T_{\text{heating overload power turn-off temperature}}]$ , you should adjust the compressor frequency by reducing 30Hz/90s till the lower limit; After it was running 90s at the lower limit, if  $T_{\text{heating overload frequency reducing temperature at normal speed}} \leq T_{\text{outer pipe}}$ , then Cooling overload protects machine stopping;

**4. Power turn-off:**

If the  $[T_{\text{heating overload power turn-off temperature}}] \leq T_{\text{inner pipe}}$ , then overload protects machine stopping; If  $T_{\text{inner pipe}} > T_{\text{heating overload frequency-limited temperature}}$  and the compressor has been stopped working for 3 minutes, the machine should be allowed to operate.

5. If the overload protection power turn-off continuously occurs for six times, it should not be resumed automatically, and you should press the ON/OFF button to resume if the fault keeps on. During the process of running, if the running time of compressor exceeds the  $t_{\text{overload protection times zero clearing time}}$  , the times of overload protection power turn-off should be cleared to recount. The mode of stopping the machine or transferring to supply air will clear the trouble times immediately (if the trouble can not be resumed, transferring mode will not clear it). Protective function for discharge temperature of compressor

**1. Starting estimation:**

After the compressor stopped working for 180s, if  $T_{\text{Discharge}} < T_{\text{Discharge limited temperature}}$  (the temperature of hysteresis is 35.6°F ), the machine is allowed to start, otherwise it should not be started, and should be stopped to treat according to the discharge temperature:

The machine should be stopped or transferred to supply air, the trouble should be cleared immediately, and the protection times are not counted.

**2. Frequency limited**

If  $[T_{\text{Limited frequency temperature during discharging}}] \leq T_{\text{Discharge}} < [T_{\text{frequency reducing temperature at normal speed during discharging}}]$  , you should limit the frequency raising of compressor.

**3. Reducing frequency at normal speed and stopping machine:**

If  $[T_{\text{frequency reducing temperature at normal speed during discharging}}] \leq T_{\text{Discharge}} < [T_{\text{frequency reducing temperature at high speed during discharging}}]$ , you should adjust the compressor frequency by reducing 8Hz/90s till the lower limit; After it was running 90s at the lower limit, if  $[T_{\text{frequency reducing temperature at normal speed during discharging}}] \leq T_{\text{Discharge}}$ , you should discharge to protect machine stopping;

**4. Reducing frequency at high speed and power turn-off:**

If  $[T_{\text{frequency reducing temperature at high speed during discharging}}] \leq T_{\text{Discharge}} < [T_{\text{Stop temperature during discharging}}]$ , you should adjust the compressor frequency by reducing 30Hz/90s till the lower limit; After it was running 90s at the lower limit, if  $[T_{\text{frequency reducing temperature at normal speed during discharging}}] \leq T_{\text{Discharge}}$ , you should discharge to protect machine stopping;

**5. Power turn-off:**

If the  $[T_{\text{Power turn-off temperature during discharging}}] \leq T_{\text{Discharge}}$ , you should discharge to protect machine stopping; If  $[T_{\text{Discharge}}] < [T_{\text{Limited frequency temperature during discharging}}]$  and the compressor has been stopped for 3 minutes, the machine should be allowed to operate.

6. If the discharging temperature protection of compressor continuously occurs for six times, it should not be resumed automatically, and you should press the ON/OFF button to resume. During the process of running, if the running time of compressor exceeds the  $t_{\text{Protection times clearing of discharge}}$  , the discharge protection is cleared to recount. Stopped or transferred to supply air mode will clear the trouble times immediately (if the trouble can not be resumed, mode transferring also will not clear it).

**7. Frequency limited**

If  $[I_{\text{Limited frequency when overcurrent}}] \leq I_{\text{AC Electric current}} < [I_{\text{frequency reducing when overcurrent}}]$ , you should limit the frequency raising of compressor.

**8. Reducing frequency:**

If  $[I_{\text{Frequency reducing when overcurrent}}] \leq [I_{\text{AC Electric current}}]$  , you should reduce the compressor frequency till the lower limit or exit the frequency reducing condition;

**9. Power turn-off:**

If  $[I_{\text{Power turn-off machine when overcurrent}}] \leq [I_{\text{AC Electric current}}]$  , you should carry out the overcurrent stopping protection; If  $I_{\text{AC Electric current}} < [I_{\text{Limited frequency when overcurrent}}]$  and the compressor has been stopped for 3 minutes, the machine should be allowed to operate.

10. If the overcurrent protection continuously occurs for six times, it should not be resumed automatically, and you should press the ON/OFF button to resume. During the process of running, if the running time of compressor exceeds the  $[t_{\text{Protection times clearing of over current}}]$  , the discharge protection is cleared to recount.

**(6)Voltage sag protection**

After start the compressor, if the time of DC link Voltage sag [ $U_{\text{Sagging protection voltage}}$ ] is measured to be less than t Voltage sag protection time , the machine should be stop at once, hand on the voltage sag trouble, reboot automatically after 30 minutes.

**(7)Communication fault**

When you have not received any correct signal from the inner machine in three minutes, the machine will stop for communication fault. When you have not received any correct signal from driver IC (aim to the controller for the separating of main control IC and driver IC), and the machine will stop for communication fault. If the communication is resumed, the machine will be allowed to operate.

**(8)Module protection**

Testing the module protective signal immediately after started, once the module protective signal is measured, stop the machine with module protection immediately. If the module protection is resumed, the machine will be allowed to operate. If the module protection continuously occurs for three times, it should not be resumed automatically, and you should press the ON/OFF button to resume. If the running time of compressor exceeds the [ $t_{\text{Protection times clearing of module}}$ ] , the module protection is cleared to recount.

**(9)Module overheating protection****1. Starting estimation:**

After the compressor stopped working for 180s, if  $T_{\text{Module}} < [T_{\text{Module frequency limited temperature}}]$  (the temperature of hysteresis is 35.6°F ), the machine is allowed to start, otherwise it should not be started, and should be stopped to treat according to the module overheating protection: The machine should be stopped or transferred to supply air, the trouble should be cleared immediately, and the protection times are not counted.

**2. Frequency limited**

If  $[T_{\text{Limited frequency temperature of module}}] \leq T_{\text{Module}} < [T_{\text{frequency reducing temperature at normal speed of module}}]$  , you should limit the frequency raising of compressor.

**3. Reducing frequency at normal speed and power turn-off:**

If  $[T_{\text{frequency reducing temperature at normal speed of module}}] \leq T_{\text{Module}} < [T_{\text{frequency reducing temperature at high speed of module}}]$  , you should adjust the compressor frequency by reducing 8Hz/90s till the lower limit; After it was running 90s at the lower limit, if  $[T_{\text{frequency reducing temperature at normal speed of module}}] \leq T_{\text{Module}}$  , you should stop the machine for module overheating protection;

**4. Reducing frequency at high speed and power turn-off:**

If  $[T_{\text{frequency reducing temperature at high speed of module}}] \leq T_{\text{Module}} < [T_{\text{Power turn-off temperature of module}}]$  you should adjust the compressor frequency by reducing 30Hz/90s till the lower limit; After it was running 90s at the lower limit, if  $[T_{\text{frequency reducing temperature at normal speed of module}}] \leq T_{\text{Module}}$  , you should stop the machine for module overheating protection;

**5. Power turn-off:**

If the  $[T_{\text{Power turn-off temperature of module}}] \leq T_{\text{Module}}$  , you should stop the machine for module overheating protection; If  $T_{\text{Module}} < [T_{\text{Limited frequency temperature of module}}]$  and the compressor has been stopped for 3 minutes, the machine should be allowed to operate.

6. If protection continuously occurs for six times, it should not be resumed automatically, and you should press the ON/OFF button to resume. During the process of running, if the running time of compressor exceeds the [ $t_{\text{Protection times clearing of module}}$ ] , the discharge protection is cleared to recount. Stopped or transferred to supply air mode will clear the trouble times immediately (if the trouble can not be resumed, mode transferring also will not clear it).

**(10)Compressor overloads protection**

If you measure the compressor overload switch action in 3s, the compressor should be stopped for overloading. The machine should be allowed to operate after overload protection was measured to resume. If the overloading protection continuously occurs for three times, it should not be resumed automatically, and you should press the ON/OFF button to resume. The protection times of compressor is allowed to clear after the compressor run [ $t_{\text{Protection times clearing of compressor overloading}}$ ] 30 minutes.

**(11)Phase current overcurrent protection of compressor**

During the running process of compressor, you could measure the phase current of the compressor, and control it according to the following steps:

**1. Frequency limited**

If  $[I_{\text{Limited frequency phase current}}] \leq [I_{\text{Phase current T frequency reducing phase current}}]$  , you should limit the frequency raising of compressor.

**2. Reducing Frequency**

If  $[I_{\text{Frequency Reducing Phase Current}}] \leq I_{\text{Phase Current}} < [I_{\text{Power Turn-Off Phase Current}}]$  , the compressor shall continue to reduce frequency till the lowest frequency limit or out of the condition of reducing frequency;

**3. Power turn-off**

If  $[I_{\text{Phase Current}}] \geq [I_{\text{Power Turn-Off Phase Current}}]$  , the compressor phase current shall stop working for overcurrent protection; if  $[I_{\text{Phase Current}}] \leq [I_{\text{Frequency Reducing Phase Current}}]$  , and the compressor have stopped working for 3 min, the machine shall be allowed to operate;

4. If the overcurrent protection of compressor phase current continuously occurs for six times, it should not be resumed automatically, and you should press the ON/OFF button to resume. During the process of running, if the running time of compressor exceeds the [ $t_{\text{Clearing Time of Compressor Phase Current Times}}$ ] , the overcurrent protection is cleared to recount.



**(12) Starting-up Failure Protection for Compressor**

Stop the compressor after its starting-up fails, restart it after 20s if the fault doesn't show, and if they are all failing for the successive start 3 times, it shall be reported as Starting-up Failure, and then restart up it after 3 min. When it still not be able to operate through carry out the above process for 5 times, it is available if press ON/OFF. And the compressor should be cleared the times after it run 2 min.

**(13) Out-of-Step Protection for Compressor**

The out-of-step protection signal should be detected immediately after starting-up compressor, and once find the out-of-step protection signal, the out-of-step protection shall be stopped; if it can run for lasting power turn-off 3 min, the machine shall be allowed to operate. If it still can't run automatically when the out-of-step protection for compressor happens to stop working for 6 times in succession, it needs to press ON/OFF to operate. And if the running time is more than 10 min, the power turn-off times for out-of-step protection shall be cleared and recounted.

**(14) Voltage Abnormity Protection for DC Bus**

To detect voltage abnormity protection for dc bus after completing the pre-charge:

**1. Over-High Voltage Protection for DC Bus:**

If it found the DC bus voltage  $U_{DC} > [UDC_{\text{Jiekuangchun Protection}}]$ , turn off PFC and stop the compressor at once, and it shall show the DC over-high voltage failure; it should clear out the failure when the voltage dropped to  $U_{DC} < [UDC_{\text{Jiekuangchun Recovery}}]$  and the compressor stopped for 3 min.

**2. Over-Low Voltage Protection for DC Bus:**

If it found the DC bus voltage  $U_{DC} < [U_{DC \text{ Wantuochun Protection}}]$ , turn off PFC and stop the compressor at once, and it shall show the DC over-low voltage; and it should clear out the failure when the voltage raised to  $U_{DC} > [U_{DC \text{ Wantuochun Recovery}}]$  and the compressor stopped for 3 min.

**3. To detect voltage abnormity protect for DC bus when getting electricity:**

If it found the DC bus voltage  $U_{DC} > [U_{DC \text{ Over-High Voltage}}]$ , turn off the relay at once, and shows voltage abnormity failure for DC Bus. And the failure can't recover except to break off and get the electricity.

**(15) Abnormity Protection for Four-way Valve**

Under the model of heating operation in good condition: the compressor is detected  $[T_{\text{Inner Tube}} < (T_{\text{Inner Ring}} - T_{\text{Abnormity Temperature Difference For Four-Way Valve Reversion}})]$ , during the running, it should be regarded as four-way valve reversion abnormity. And then it can run if stop the reversion abnormity protection for four-way valve 3 min; and if it still can't run when the reversion abnormity protection for four-way valve happens to stop working for 3 times in succession, it is available if presses ON/OFF.

Attention: the protection shall be shielded during the testing mode and defrosting process, and it shall be cleared out the failure and its times immediately when turning off or delivering wind / cooling / dehumidifying mode conversed (the inverted mode don't clear out the failure when it can't recover to operate).

**(16) PFC Protection**

1. After start up the PFC, it should detect the protection signal of PFC immediately; under the condition of PFC protection, it should turn off the PFC and compressor at one time;
2. It shows the failure is cleared out if PFC Protection stopped working 3 min and recovers to run automatically;
3. If it still can't run when it occurs PFC protection for 3 times in succession, it is available if presses ON/OFF; and clear the PFC Protection times when start up PFC for 10min.

**(17) Failure Detection for Sensor**

1. Outdoor Ambient Sensor: detect the failure of sensor at all times.
2. Outdoor Tube Sensor: You should not detect the failure of outdoor tube sensor within 10 minutes heating operation compressor except the defrosting, and you could detect it at other time.
3. Outdoor Exhaust Sensor:
  - (a) The compressor only detect the sensor failure after it start up 3 min in normal mode;
  - (b) It should detect the exhaust sensor failure immediately in the testing mode.
4. Module Temperature Sensor:
  - (a) Short-Circuit Detection: the compressor should be detected immediately when the module temperature sensor occurs short-circuits;
  - (b) Open-Circuit Detection: the compressor should be detected on open-circuit when it runs 3min (it needn't 30s avoiding the module over-heated).
  - (c) Detect the sensor failure at all times in the testing mode.
5. Disposal for Sensor Protection
  - (1) When the short-circuit of sensor is detected within 30s, It is regarded as the temperature of sensor over-high (or infinitely high), and now according to the over-high sensor, the machine should carry out the corresponding protection to stop working, and show the corresponding temperature shutdown protection and sensor failure at the same time (for example: the compressor stops immediately when the outdoor tube sensor short-circuit, and the machine shall show the overload protection and outdoor tube sensor failure).
  - (2) When the open-circuit of sensor is detected within 30s, The protection shall be stopped and it shall show the corresponding sensor failure.

6. Electric Heating Function of Chassis

- (1) When  $T_{\text{outdoor amb.}} \leq 32^{\circ}\text{F}$  , the electric heating of chassis will operate;
- (2) When  $T_{\text{outdoor amb.}} > 35.6^{\circ}\text{F}$  , the electric heating of chassis will stop operation;
- (3) When  $32^{\circ}\text{F} < T_{\text{outdoor amb.}} \leq 35.6^{\circ}\text{F}$  , the electric heating of chassis will keep original status.

7. Electric Heating Function of Compressor

- (1) When  $T_{\text{outdoor amb.}} \leq 23^{\circ}\text{F}$  , compressor stops operation, while the electric heating of compressor starts operation;
- (2) When  $T_{\text{outdoor amb.}} > 28.4^{\circ}\text{F}$  , the electric heating of compressor stops operation;
- (3) When  $23^{\circ}\text{F} < T_{\text{outdoor amb.}} \leq 28.4^{\circ}\text{F}$  , the electric heating of compressor will keep original status.

# Part II : Installation and Maintenance

## 7. Notes for Installation and Maintenance

### Safety Precautions:

#### Important!

Please read the safety precautions carefully before installation and maintenance.

The following contents are very important for installation and maintenance.

Please follow the instructions below.

- The installation or maintenance must accord with the instructions.
- Comply with all national electrical codes and local electrical codes.
- Pay attention to the warnings and cautions in this manual.
- All installation and maintenance shall be performed by distributor or qualified person.
- All electric work must be performed by a licensed technician according to local regulations and the instructions given in this manual.
- Be caution during installation and maintenance. Prohibit incorrect operation to prevent electric shock, casualty and other accidents.



## Warnings

#### Electrical Safety Precautions:

1. Cut off the power supply of air conditioner before checking and maintenance.
2. The air condition must apply specialized circuit and prohibit share the same circuit with other appliances.
3. The air conditioner should be installed in suitable location and ensure the power plug is touchable.
4. Make sure each wiring terminal is connected firmly during installation and maintenance.
5. Have the unit adequately grounded. The grounding wire cant be used for other purposes.
6. Must apply protective accessories such as protective boards, cable-cross loop and wire clip.
7. The live wire, neutral wire and grounding wire of power supply must be corresponding to the live wire, neutral wire and grounding wire of the air conditioner.
8. The power cord and power connection wires cant be pressed by hard objects.
9. If power cord or connection wire is broken, it must be replaced by a qualified person.
10. If the power cord or connection wire is not long enough, please get the specialized power cord or connection wire from the manufacture or distributor.

Prohibit prolong the wire by yourself.

11. For the air conditioner without plug, an air switch must be installed in the circuit. The air switch should be all-pole parting and the contact parting distance should be more than 1/8 inch.
12. Make sure all wires and pipes are connected properly and the valves are opened before energizing.
13. Check if there is electric leakage on the unit body. If yes, please eliminate the electric leakage.
14. Replace the fuse with a new one of the same specification if it is burnt down; dont replace it with a cooper wire or conducting wire.
15. If the unit is to be installed in a humid place, the circuit breaker must be installed.

#### Installation Safety Precautions:

1. Select the installation location according to the requirement of this manual.(See the requirements in installation part)
2. Handle unit transportation with care; the unit should not be carried by only one person if it is more than 44.09lb.
3. When installing the indoor unit and outdoor unit, a sufficient fixing bolt must be installed; make sure the installation support is firm.
4. Ware safety belt if the height of working is above 78 3/4 inch.
5. Use equipped components or appointed components during installation.
6. Make sure no foreign objects are left in the unit after finishing installation.

#### Refrigerant Safety Precautions:

When refrigerant leaks or requires discharge during installation, maintenance, or disassembly, it should be handled by certified professionals or otherwise in compliance with local laws and regulations.

1. Avoid contact between refrigerant and fire as it generates poisonous gas; Prohibit prolong the connection pipe by welding.
2. Apply specified refrigerant only. Never have it mixed with any other refrigerant. Never have air remain in the refrigerant line as it may lead to rupture or other hazards.
3. Make sure no refrigerant gas is leaking out when installation is completed.
4. If there is refrigerant leakage, please take sufficient measure to minimize the density of refrigerant.
5. Never touch the refrigerant piping or compressor without wearing glove to avoid scald or frostbite.

Improper installation may lead to fire hazard, explosion, electric shock or injury.

# Safety Precautions for Installing and Relocating the Unit:

To ensure safety, please be mindful of the following precautions.



## Warnings

**1. When installing or relocating the unit, be sure to keep the refrigerant circuit free from air or substances other than the specified refrigerant.**

Any presence of air or other foreign substance in the refrigerant circuit will cause system pressure rise or compressor rupture, resulting in injury.

**2. When installing or moving this unit, do not charge the refrigerant which is not comply with that on the nameplate or unqualified refrigerant.**

Otherwise, it may cause abnormal operation, wrong action, mechanical malfunction or even series safety accident.

**3. When refrigerant needs to be recovered during relocating or repairing the unit, be sure that the unit is running in cooling mode. Then, fully close the valve at high pressure side (liquid valve). About 30-40 seconds later, fully close the valve at low pressure side (gas valve), immediately stop the unit and disconnect power. Please note that the time for refrigerant recovery should not exceed 1 minute.**

If refrigerant recovery takes too much time, air may be sucked in and cause pressure rise or compressor rupture, resulting in injury.

**4. During refrigerant recovery, make sure that liquid valve and gas valve are fully closed and power is disconnected before detaching the connection pipe.**

If compressor starts running when stop valve is open and connection pipe is not yet connected, air will be sucked in and cause pressure rise or compressor rupture, resulting in injury.

**5. When installing the unit, make sure that connection pipe is securely connected before the compressor starts running.**

If compressor starts running when stop valve is open and connection pipe is not yet connected, air will be sucked in and cause pressure rise or compressor rupture, resulting in injury.

**6. Prohibit installing the unit at the place where there may be leaked corrosive gas or flammable gas.**

If there leaked gas around the unit, it may cause explosion and other accidents.

**7. Do not use extension cords for electrical connections. If the electric wire is not long enough, please contact a local service center authorized and ask for a proper electric wire.**

Poor connections may lead to electric shock or fire.

**8. Use the specified types of wires for electrical connections between the indoor and outdoor units. Firmly clamp the wires so that their terminals receive no external stresses.**

Electric wires with insufficient capacity, wrong wire connections and insecure wire terminals may cause electric shock or fire.

# Main Tools for Installation and Maintenance

<p>1. Level meter, measuring tape</p> 	<p>2. Screw driver</p> 	<p>3. Impact drill, drill head, electric drill</p> 
<p>4. Electroprobe</p> 	<p>5. Universal meter</p> 	<p>6. Torque wrench, open-end wrench, inner hexagon spanner</p> 
<p>7. Electronic leakage detector</p> 	<p>8. Vacuum pump</p> 	<p>9. Pressure meter</p> 
<p>10. Pipe pliers, pipe cutter</p> 	<p>11. Pipe expander, pipe bender</p> 	<p>12. Soldering appliance, refrigerant container, electronic scale</p> 

## 8. Installation

### 8.1 Installation Dimension Diagram

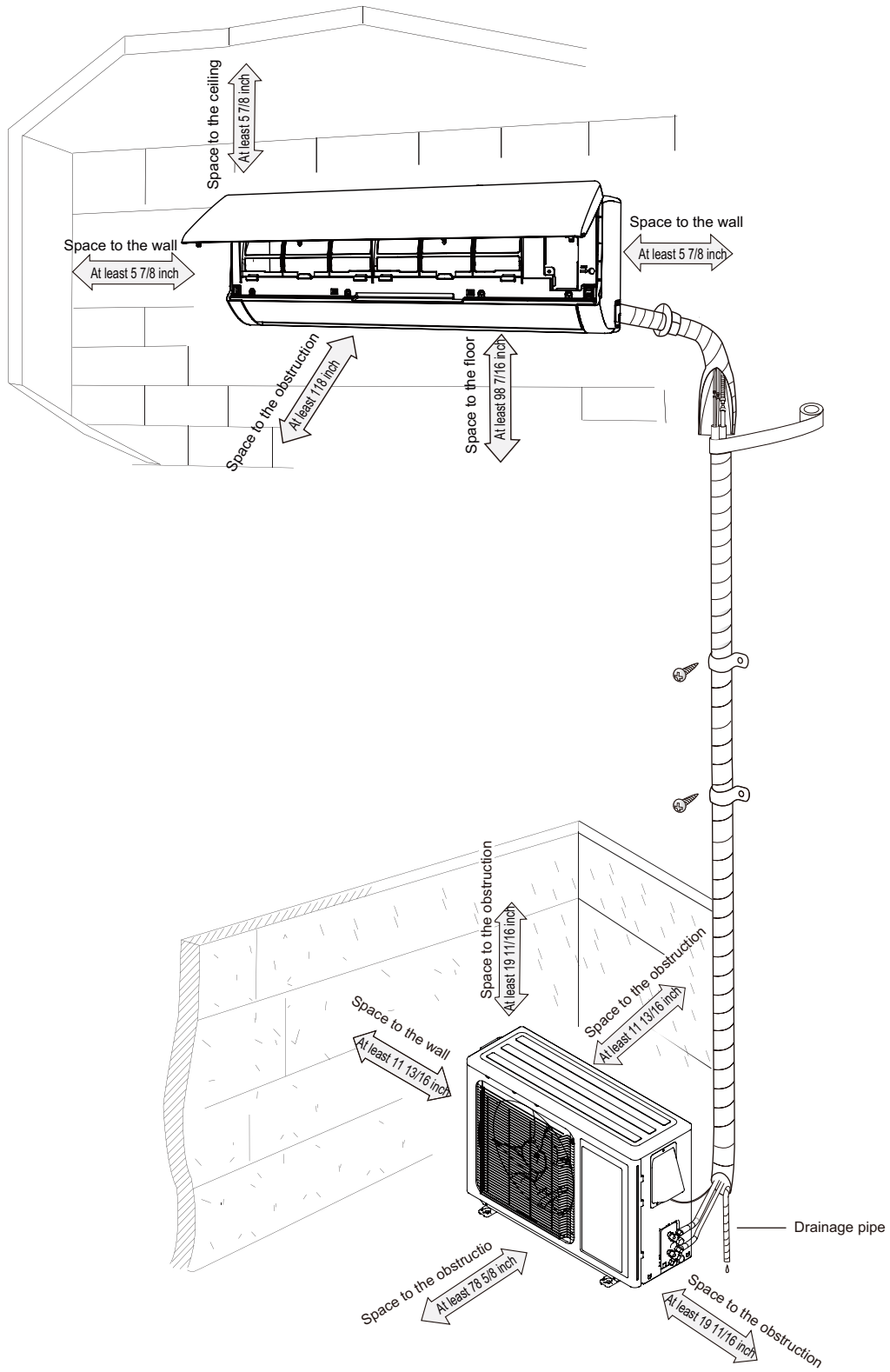

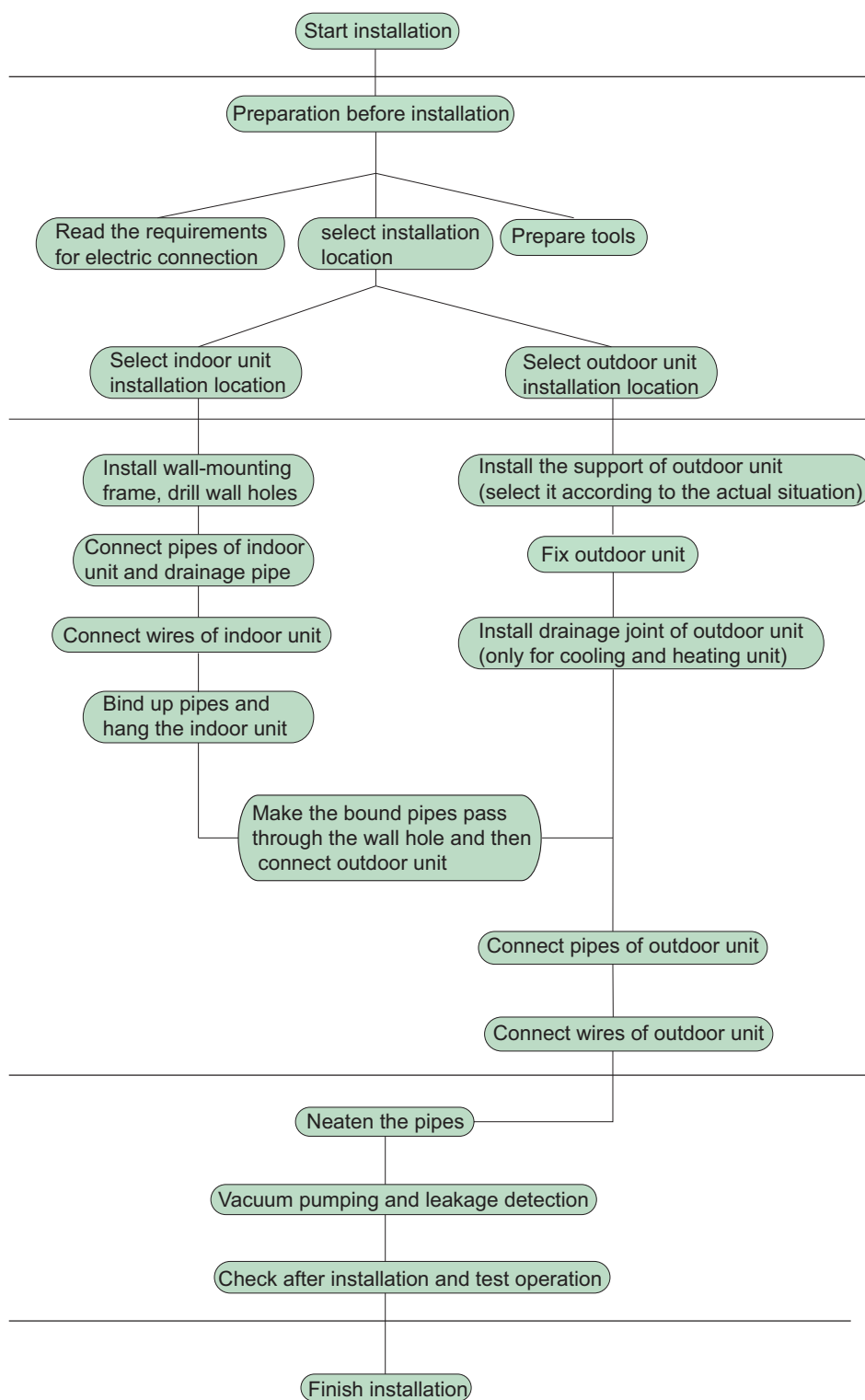

Note: this flow is only for reference; please find the more detailed installation steps in this section.



## 8.2 Installation Parts-checking

No.	Name	No.	Name
1	Indoor unit	8	Sealing gum
2	Outdoor unit	9	Wrapping tape
3	Connection pipe	10	Support of outdoor unit
4	Drainage pipe	11	Fixing screw
5	Wall-mounting frame	12	Drainage plug(cooling and heating unit)
6	Connecting cable(power cord)	13	Owners manual, remote controller
7	Wall pipe		

**⚠ Note:**

- 1.Please contact the local agent for installation.
- 2.Dont use unqualified power cord.

## 8.3 Selection of Installation Location

### 1. Basic Requirement:

Installing the unit in the following places may cause malfunction. If it is unavoidable, please consult the local dealer:

- (1) The place with strong heat sources, vapors, flammable or explosive gas, or volatile objects spread in the air.
- (2) The place with high-frequency devices (such as welding machine, medical equipment).
- (3) The place near coast area.
- (4) The place with oil or fumes in the air.
- (5) The place with sulfureted gas.
- (6) Other places with special circumstances.
- (7) The appliance shall not be install-ed in the laundry.
- (8) It's not allowed to be installed on the unstable or motive base structure (such as truck) or in the corrosive environment (such as chemical factory).

### 2. Indoor Unit:

- (1) There should be no obstruction near air inlet and air outlet.
- (2) Select a location where the condensation water can be dispersed easily and wont affect other people.
- (3) Select a location which is convenient to connect the outdoor unit and near the power socket.
- (4) Select a location which is out of reach for children.
- (5) The location should be able to withstand the weight of indoor unit and wont increase noise and vibration.
- (6) The appliance must be installed 72inch above floor.
- (7) Dont install the indoor unit right above the electric appliance.
- (8) Please try your best to keep way from fluorescent lamp.

### 3. Outdoor Unit:

- (1) Select a location where the noise and outflow air emitted by the outdoor unit will not affect neighborhood.
- (2) The location should be well ventilated and away from strong wind.
- (3) The location should be able to withstand the weight of outdoor unit.
- (4) Make sure that the installation follows the requirement of installation dimension diagram.
- (5) Select a location which is out of reach for children and far away from animals or plants.If it is unavoidable, please add fence for safety purpose.

## 8.4 Requirements for Electric Connection

### 1. Safety Precaution

- (1) Must follow the electric safety regulations when installing the unit.
- (2) According to the local safety regulations, use qualified power supply circuit and air switch.
- (3) Make sure the power supply matches with the requirement of air conditioner. Unstable power supply or incorrect wiring may result in electric shock,fire hazard or malfunction. Please install proper power supply cables before using the air conditioner.
- (4) Properly connect the live wire, neutral wire and grounding wire of power socket.
- (5) Be sure to cut off the power supply before proceeding any work related to electricity and safety.
- (6) Do not put through the power before finishing installation.
- (7) If the supply cord is damaged,it must be replaced by the manufacturer,its service agent or similarly qualified persons in order to avoid a hazard.
- (8) The temperature of refrigerant circuit will be high, please keep the interconnection cable away from the copper tube.
- (9) The appliance shall be installed in accordance with national wiring regulations.

### 2. Grounding Requirement:

- (1) The air conditioner is first class electric appliance. It must be properly grounding with specialized grounding device by a professional. Please make sure it is always grounded effectively, otherwise it may cause electric shock.
- (2) The yellow-green wire in air conditioner is grounding wire, which cant be used for other purposes.
- (3) The grounding resistance should comply with national electric safety regulations.
- (4) The appliance must be positioned so that the plug is accessible.
- (5) An all-pole disconnection switch having a contact separation of at least 1/8 inch in all poles should be connected in fixed wiring.
- (6) Including an air switch with suitable capacity, please note the following table. Air switch should be included magnet buckle and heating buckle function, it can protect the circuit-short and overload. (Caution: please do not use the fuse only for protect the circuit)

Air-conditioner	Air switch capacity
09/12K	15A

## 8.5 Installation of Indoor Unit

### 1. Choosing Installation location

Recommend the installation location to the client and then confirm it with the client.

### 2. Install Wall-mounting Frame

- (1) Hang the wall-mounting frame on the wall; adjust it in horizontal position with the level meter and then point out the screw fixing holes on the wall.
- (2) Drill the screw fixing holes on the wall with impact drill (the specification of drill head should be the same as the plastic expansion particle) and then fill the plastic expansion particles



in the holes.

(3) Fix the wall-mounting frame on the wall with tapping screws and then check if the frame is firmly installed by pulling the frame. If the plastic expansion particle is loose, please drill another fixing hole nearby.

### 3. Install Wall-mounting Frame

(1) Choose the position of piping hole according to the direction of outlet pipe. The position of piping hole should be a little lower than the wall-mounted frame.(As show in Fig.1)

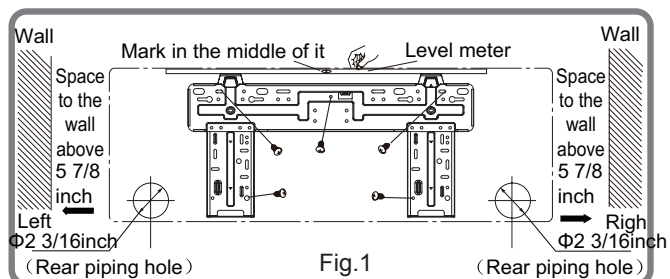

(2) Open a piping hole with the diameter of 2 3/16inch on the selected outlet pipe position. In order to drain smoothly, slant the piping hole on the wall slightly downward to the outdoor side with the gradient of 5-10°.(As show in Fig.2)

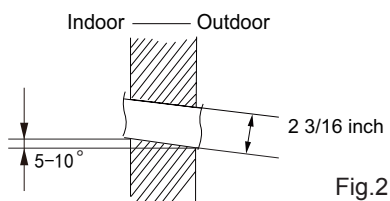

#### ⚠ Note:

(1) Pay attention to dust prevention and take relevant safety measures when opening the hole.

### 4. Outlet Pipe

(1) The pipe can be led out in the direction of right, rear right, left or rear left.(As show in Fig.3)  
 (2) When selecting leading out the pipe from left or right, please cut off the corresponding hole on the bottom case.(As show in Fig.4)

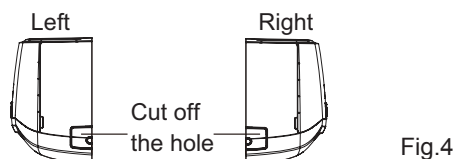
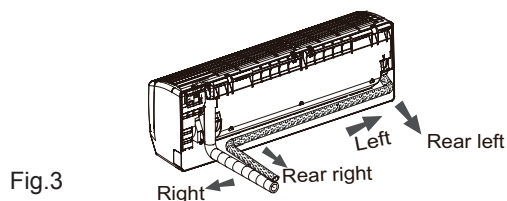

### 5. Connect the Pipe of Indoor Unit

(1) Aim the pipe joint at the corresponding bellmouth.(As show in Fig.5)  
 (2) Pretightening the union nut with hand.  
 (3) Adjust the torque force by referring to the following sheet. Place the open-end wrench on the pipe joint and place the torque wrench on the union nut. Tighten the union nut with torque wrench.(As show in Fig.6)  
 (4) Wrap the indoor pipe and joint of connection pipe with insulating pipe, and then wrap it with tape.(As show in Fig.7)

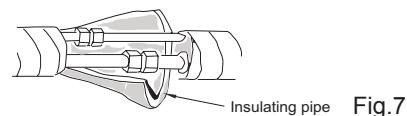
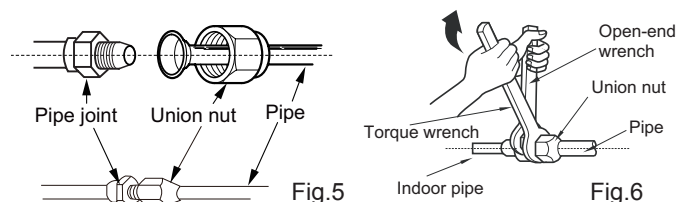

Refer to the following table for wrench moment of force:

Hex nut diameter(inch)	Tightening torque(ft·lbf)
Φ1/4	11.10~14.75
Φ3/8	22.12~29.50
Φ1/2	33.19~40.56
Φ5/8	44.24~47.94
Φ3/4	51.32~55.31

### 6. Install Drain Hose

(1) Connect the drain hose to the outlet pipe of indoor unit.(As show in Fig.8)  
 (2) Bind the joint with tape.(As show in Fig.9)

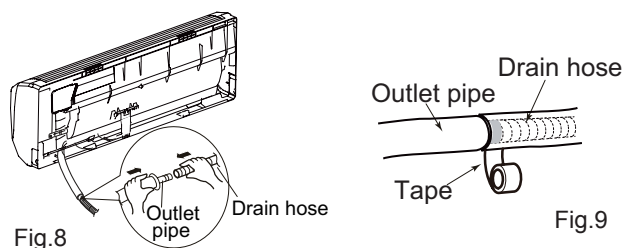

#### ⚠ Note:

(1) Add insulating pipe in the indoor drain hose in order to prevent condensation.  
 (2) The plastic expansion particles are not provided.(As show in Fig.10)

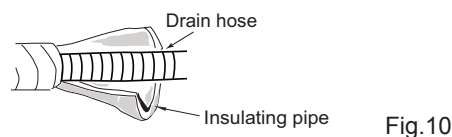

### 7. Connect Wire of Indoor Unit

(1) Open the panel, remove the screw on the wiring cover and then take down the cover.(As show in Fig.11)

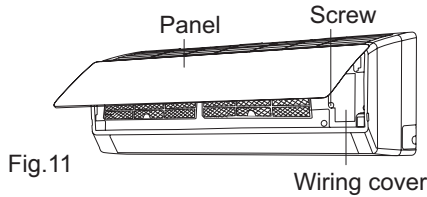

(2) Fix the wire crossing board on connection wire sleeve at the bottom case; let the connection wire sleeve go through the wire crossing hole at the back of indoor unit, and then pull it out from the front.(As show in Fig.12)

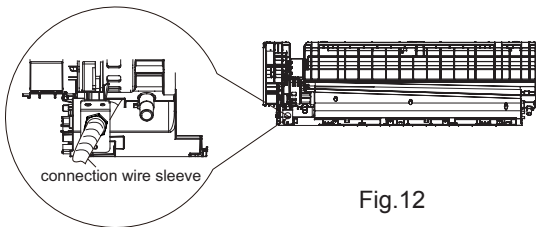

(3) Remove the wire clip; connect the power connection wire to the wiring terminal; tighten the screw and then fix the power connection wire with wire clip.(As show in Fig.13)

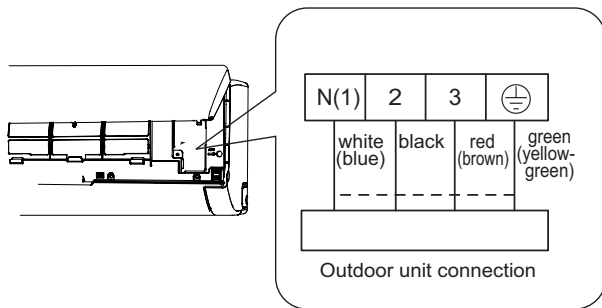

Note: the wiring board is for reference only, please refer to the actual one.

Fig.13

(4) Put wiring cover back and then tighten the screw.  
(5) Close the panel.

**⚠ Note:**

- (1) All wires of indoor unit and outdoor unit should be connected by a professional.
- (2) If the length of power connection wire is insufficient, please contact the supplier for a new one. Avoid extending the wire by yourself.
- (3) For the air conditioner with plug, the plug should be reachable after finishing installation.
- (4) For the air conditioner without plug, an air switch must be installed in the line. The air switch should be all-pole parting and the contact parting distance should be more than 3mm.

### 8. Bind up Pipe

- (1) Bind up the connection pipe, power cord and drain hose with the band.(As show in Fig.14)
- (2) Reserve a certain length of drain hose and power cord for installation when binding to a certain degree, separate the indoor power and then separate the drain hose.(As show in Fig.15)
- (3) Bind them evenly.
- (4) The liquid pipe and gas pipe should be bound separately at the end.

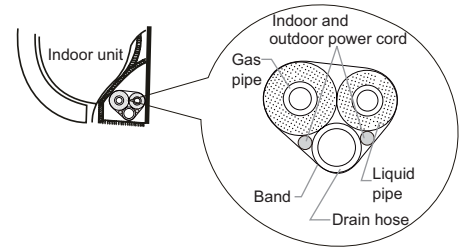

Fig.14

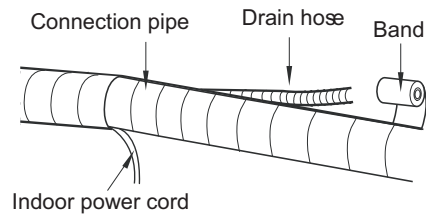

Fig.15

**⚠ Note:**

- (1) The power cord and control wire cant be crossed or winding.
- (2) The drain hose should be bound at the bottom.

### 9. Hang the Indoor Unit

- (1) Put the bound pipes in the wall pipe and then make them pass through the wall hole.
- (2) Hang the indoor unit on the wall-mounting frame.
- (3) Stuff the gap between pipes and wall hole with sealing gum.
- (4) Fix the wall pipe.(As show in Fig.16)
- (5) Check if the indoor unit is installed firmly and closed to the wall.(As show in Fig.17)

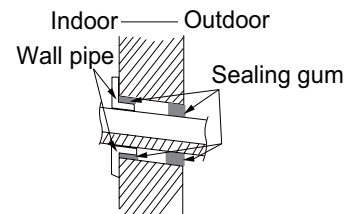

Fig.16

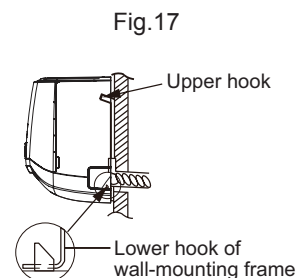

Fig.17

**⚠ Note:**

Do not bend the drain hose too excessively in order to prevent blocking.

## 8.6 Installation of Outdoor Unit

### 1. Fix the Support of Outdoor Unit(Select it according to the actual installation situation)

- (1) Select installation location according to the house structure.
- (2) Fix the support of outdoor unit on the selected location with expansion screws.

**⚠ Note:**

- (1) Take sufficient protective measures when installing the outdoor unit.
- (2) Make sure the support can withstand at least four times the unit weight.
- (3) The outdoor unit should be installed at least 1 3/16 inch above the floor in order to install drain joint.(As show in Fig.18)
- (4) For the unit with cooling capacity of 2300W~5000W, 6 expansion screws are needed; for the unit with cooling capacity of 6000W~8000W, 8 expansion screws are needed; for the unit with cooling capacity of 10000W~16000W, 10 expansion screws are needed.

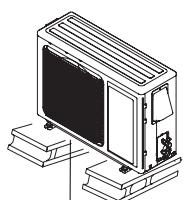

Fig.18

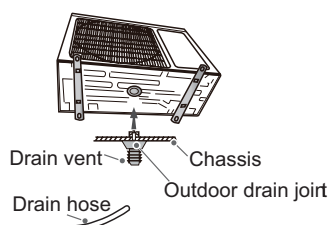

Fig.19

### 2. Install Drain Joint(only for cooling and heating unit)

- (1) Connect the outdoor drain joint into the hole on the chassis.
  - (2) Connect the drain hose into the drain vent.
- (As show in Fig.19)

### 3. Fix Outdoor Unit

- (1) Place the outdoor unit on the support.
  - (2) Fix the foot holes of outdoor unit with bolts.
- (As show in Fig.20)

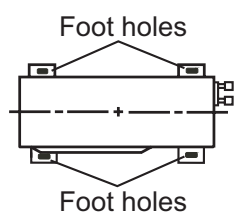

Fig.20

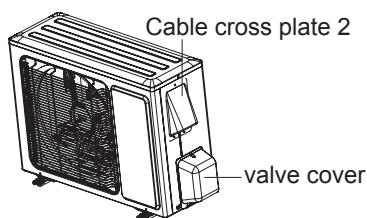

Fig.21

### 4. Connect Indoor and Outdoor Pipes

- (1) Remove the screw on the cable cross plate 2 and valve cover of outdoor unit and then remove the cable cross plate 2 and valve cover.(As show in Fig.21)
- (2) Remove the screw cap of valve and aim the pipe joint at the bellmouth of pipe.(As show in Fig.22)

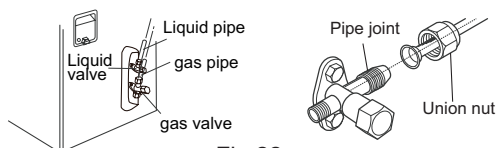

Fig.22

- (3) Pretightening the union nut with hand.
- (4) Tighten the union nut with torque wrench .

Refer to the following table for wrench moment of force:

Hex nut diameter(inch)	Tightening torque(ft·lbf)
Φ1/4	11.10~14.75
Φ3/8	22.12~29.50
Φ1/2	33.19~40.56
Φ5/8	44.24~47.94
Φ3/4	51.32~55.31

### 5. Connect Outdoor Electric Wire

- (1) Let the connection wire sleeve go through the two holes of baffle; tighten the connection joint of sleeve and baffle; remove the wire clip; connect the power connection wire and power cord to the wiring terminal according to the color; fix them with screws.(As show in Fig.23)

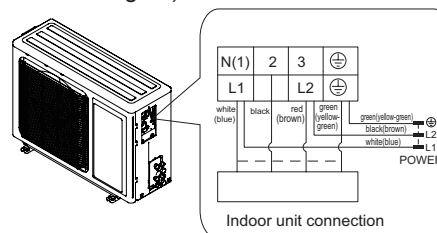

Fig.23

Note: the wiring board is for reference only, please refer to the actual one.

- (2) Fix the power connection wire and power cord with wire clip.
- (3) Fix the stopper on handle with screw.

**⚠ Note:**

- (1) After tightening the screw, pull the power cord slightly to check if it is firm.
- (2) Never cut the power connection wire to prolong or shorten the distance.
- (3)The connecting wire and connection pipe cannot touch each other,
- (4)Top cover of outdoor unit and electric box assembly should be fixed by the screw.Otherwise,it can cause a fire,or short circuit caused by water or dust.

### Install the over line pipe

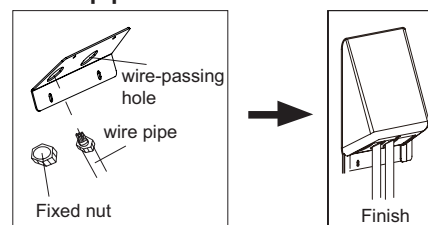

### 6. Neaten the Pipes

- (1) The pipes should be placed along the wall, bent reasonably and hidden possibly. Min. semidiameter of bending the pipe is 3 15/16inch.
- (2) If the outdoor unit is higher than the wall hole, you must set a U-shaped curve in the pipe before pipe goes into the room, in order to prevent rain from getting into the room.(As show in Fig.24)

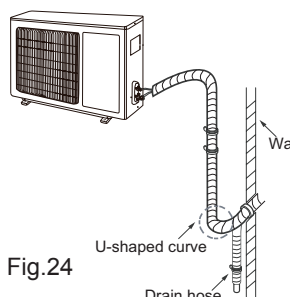

Fig.24

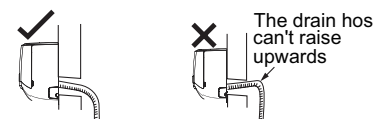
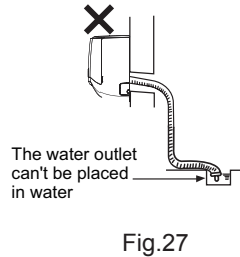
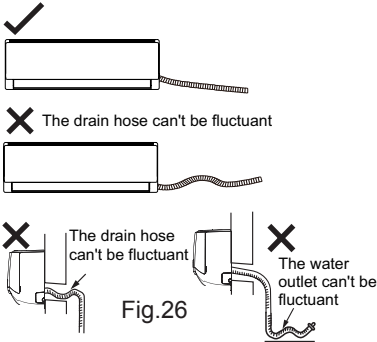

Fig.25

**⚠ Note:**

- (1) The through-wall height of drain hose shouldnt be higher than the outlet pipe hole of indoor unit.(As show in Fig.25)
- (2) Slant the drain hose slightly downwards. The drain hose cant be curved, raised and fluctuant, etc.(As show in Fig.26)
- (3) The water outlet cant be placed in water in order to drain smoothly.(As show in Fig.27)



## 8.7 Vacuum Pumping and Leak Detection

### 1. Use Vacuum Pump

- (1) Remove the valve caps on the liquid valve and gas valve and the nut of refrigerant charging vent.
- (2) Connect the charging hose of piezometer to the refrigerant charging vent of gas valve and then connect the other charging hose to the vacuum pump.
- (3) Open the piezometer completely and operate for 10-15min to check if the pressure of piezometer remains in -14.5ISP.
- (4) Close the vacuum pump and maintain this status for 1-2min to check if the pressure of piezometer remains in -14.5ISP. If the pressure decreases, there may be leakage.
- (5) Remove the piezometer, open the valve core of liquid valve and gas valve completely with inner hexagon spanner.
- (6) Tighten the screw caps of valves and refrigerant charging vent.(As show in Fig.28)

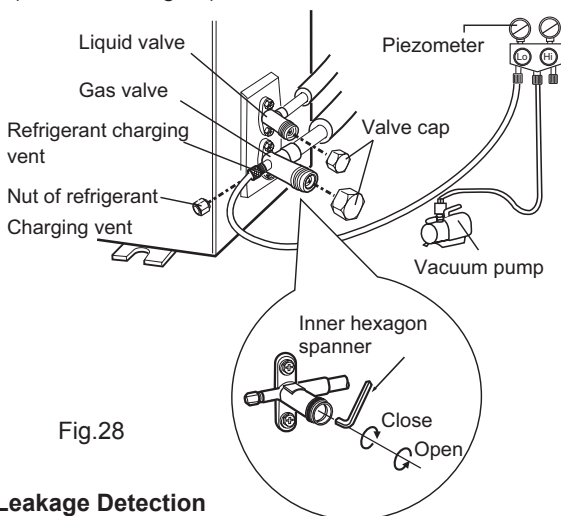

### 2. Leakage Detection

- (1) With leakage detector:  
Check if there is leakage with leakage detector.
- (2) With soap water:  
If leakage detector is not available, please use soap water for leakage detection. Apply soap water at the suspected position and keep the soap water for more than 3min. If there are air bubbles coming out of this position, theres a leakage.

## 8.8 Check after Installation and Test Operation

### 1. Check after Installation

Check according to the following requirement after finishing installation.

NO.	Items to be checked	Possible malfunction
1	Has the unit been installed firmly?	The unit may drop, shake or emit noise.
2	Have you done the refrigerant leakage test?	It may cause insufficient cooling (heating) capacity.
3	Is heat insulation of pipeline sufficient?	It may cause condensation and water dripping.
4	Is water drained well?	It may cause condensation and water dripping.
5	Is the voltage of power supply according to the voltage marked on the nameplate?	It may cause malfunction or damage the parts.
6	Is electric wiring and pipeline installed correctly?	It may cause malfunction or damage the parts.
7	Is the unit grounded securely?	It may cause electric leakage.
8	Does the power cord follow the specification?	It may cause malfunction or damage the parts.
9	Is there any obstruction in air inlet and air outlet?	It may cause insufficient cooling (heating) capacity.
10	The dust and sundries caused during installation are removed?	It may cause malfunction or damaging the parts.
11	The gas valve and liquid valve of connection pipe are open completely?	It may cause insufficient cooling (heating) capacity.
12	Is the inlet and outlet of piping hole been covered?	It may cause insufficient cooling (heating) capacity or waster eletricity.

### 2. Test Operation

- (1) Preparation of test operation
  - The client approves the air conditioner installation.
  - Specify the important notes for air conditioner to the client.
- (2) Method of test operation
  - Put through the power, press ON/OFF button on the remote controller to start operation.
  - Press MODE button to select AUTO, COOL, DRY, FAN and HEAT to check whether the operation is normal or not.
  - If the ambient temperature is lower than 16°C , the air conditioner cant start cooling.

## 9. Maintenance

### 9.1 Error Code List

NO.	Malfunction Name	Display Method of Indoor Unit			A/C status	Possible Causes	
		Dual-8 Code	Indicator Display (during blinking, ON 0.5s and OFF 0.5s)				
		Display	Operation Indicator	Cool Indicator	Heating Indicator		
1	High pressure protection of system	E1				During cooling and drying operation, except indoor fan operates, all loads stop operation. During heating operation, the complete unit stops.	Possible reasons: 1. Refrigerant was superabundant; 2. Poor heat exchange (including filth blockage of heat exchanger and bad radiating environment ); Ambient temperature is too high.
2	Antifreezing protection	E2				During cooling and drying operation, compressor and outdoor fan stop while indoor fan operates.	1. Poor air-return in indoor unit; 2. Fan speed is abnormal; 3. Evaporator is dirty.
3	System block or refrigerant leakage	E3				The Dual-8 Code Display will show E3 until the low pressure switch stop operation.	1.Low-pressure protection 2.Low-pressure protection of system 3.Low-pressure protection of compressor
4	High discharge temperature protection of compressor	E4				During cooling and drying operation, compressor and outdoor fan stop while indoor fan operates. During heating operation, all loads stop.	Please refer to the malfunction analysis (discharge protection, overload).
5	Overcurrent protection	E5				During cooling and drying operation, compressor and outdoor fan stop while indoor fan operates. During heating operation, all loads stop.	1. Supply voltage is unstable; 2. Supply voltage is too low and load is too high; 3. Evaporator is dirty.
6	Communication Malfunction	E6				During cooling operation, compressor stops while indoor fan motor operates. During heating operation, the complete unit stops.	Refer to the corresponding malfunction analysis.
7	High temperature resistant protection	E8				During cooling operation: compressor will stop while indoor fan will operate. During heating operation, the complete unit stops.	Refer to the malfunction analysis (overload, high temperature resistant).
8	EEPROM malfunction	EE				During cooling and drying operation, compressor will stop while indoor fan will operate; During heating operation, the complete unit will stop	Replace outdoor control panel AP1
9	Limit/ decrease frequency due to high temperature of module	EU				All loads operate normally, while operation frequency for compressor is decreased	Discharging after the complete unit is de-energized for 20mins, check whether the thermal grease on IPM Module of outdoor control panel AP1 is sufficient and whether the radiator is inserted tightly. If its no use, please replace control panel AP1.
10	Malfunction protection of jumper cap	C5				Wireless remote receiver and button are effective, but can not dispose the related command	1. No jumper cap insert on mainboard. 2. Incorrect insert of jumper cap. 3. Jumper cap damaged. 4. Abnormal detecting circuit of mainboard.



NO.	Malfunction Name	Display Method of Indoor Unit			A/C status	Possible Causes	
		Dual-8 Code Display	Indicator Display (during blinking, ON 0.5s and OFF 0.5s)				
			Operation Indicator	Cool Indicator	Heating Indicator		
11	Gathering refrigerant	F0				When the outdoor unit receive signal of Gathering refrigerant ,the system will be forced to run under cooling mode for gathering refrigerant	Nominal cooling mode
12	Indoor ambient temperature sensor is open/short circuited	F1				During cooling and drying operation, indoor unit operates while other loads will stop; during heating operation, the complete unit will stop operation.	1. Loosening or bad contact of indoor ambient temp. sensor and mainboard terminal. 2. Components in mainboard fell down leads short circuit. 3. Indoor ambient temp. sensor damaged.(check with sensor resistance value chart) 4. Mainboard damaged.
13	Indoor evaporator temperature sensor is open/short circuited	F2				AC stops operation once reaches the setting temperature. Cooling, drying: internal fan motor stops operation while other loads stop operation; heating: AC stop operation	1. Loosening or bad contact of Indoor evaporator temp. sensor and mainboard terminal. 2. Components on the mainboard fall down leads short circuit. 3. Indoor evaporator temp. sensor damaged.(check temp. sensor value chart for testing) 4. Mainboard damaged.
14	Outdoor ambient temperature sensor is open/short circuited	F3				During cooling and drying operating, compressor stops while indoor fan operates; During heating operation, the complete unit will stop operation	Outdoor temperature sensor hasnt been connected well or is damaged. Please check it by referring to the resistance table for temperature sensor)
15	Outdoor condenser temperature sensor is open/short circuited	F4				During cooling and drying operation, compressor stops while indoor fan will operate; During heating operation, the complete unit will stop operation.	Outdoor temperature sensor hasnt been connected well or is damaged. Please check it by referring to the resistance table for temperature sensor)
16	Outdoor discharge temperature sensor is open/short circuited	F5				During cooling and drying operation, compressor will sop after operating for about 3 mins, while indoor fan will operate; During heating operation, the complete unit will stop after operating for about 3 mins.	1.Outdoor temperature sensor hasnt been connected well or is damaged. Please check it by referring to the resistance table for temperature sensor) 2.The head of temperature sensor hasnt been inserted into the copper tube
17	Limit/ decrease frequency due to overload	F6				All loads operate normally, while operation frequency for compressor is decreased	Refer to the malfunction analysis (overload, high temperature resistant)
18	Decrease frequency due to overcurrent	F8				All loads operate normally, while operation frequency for compressor is decreased	The input supply voltage is too low; System pressure is too high and overload

NO.	Malfunction Name	Display Method of Indoor Unit				A/C status	Possible Causes
		Dual-8 Code Display	Indicator Display (during blinking, ON 0.5s and OFF 0.5s)				
			Operation Indicator	Cool Indicator	Heating Indicator		
19	Decrease frequency due to high air discharge	F9				All loads operate normally, while operation frequency for compressor is decreased	Overload or temperature is too high; Refrigerant is insufficient; Malfunction of electric expansion valve (EKV)
20	Limit/decrease frequency due to antifreezing	FH				All loads operate normally, while operation frequency for compressor is decreased	Poor air-return in indoor unit or fan speed is too low
21	Voltage for DC bus-bar is too high	PH				During cooling and drying operation, compressor will stop while indoor fan will operate; During heating operation, the complete unit will stop operation.	1. Measure the voltage of position L and N on wiring board (XT), if the voltage is higher than 265VAC, turn on the unit after the supply voltage is increased to the normal range. 2.If the AC input is normal, measure the voltage of electrolytic capacitor C on control panel (AP1), if its normal, theres malfunction for the circuit, please replace the control panel (AP1)
22	Voltage of DC bus-bar is too low	PL				During cooling and drying operation, compressor will stop while indoor fan will operate; During heating operation, the complete unit will stop	1. Measure the voltage of position L and N on wiring board (XT), if the voltage is higher than 150VAC, turn on the unit after the supply voltage is increased to the normal range. 2.If the AC input is normal, measure the voltage of electrolytic capacitor C on control panel (AP1), if its normal, theres malfunction for the circuit, please replace the control panel (AP1)
23	Compressor Min frequency in test state	P0					Showing during min. cooling or min. heating test
24	Compressor rated frequency in test state	P1					Showing during nominal cooling or nominal heating test
25	Compressor maximum frequency in test state	P2					Showing during max. cooling or max. heating test

NO.	Malfunction Name	Display Method of Indoor Unit			A/C status	Possible Causes	
		Dual-8 Code Display	Indicator Display (during blinking, ON 0.5s and OFF 0.5s)				
			Operation Indicator	Cool Indicator			Heating Indicator
26	Compressor intermediate frequency in test state	P3				Showing during middle cooling or middle heating test	
27	Overcurrent protection of phase current for compressor	P5			During cooling and drying operation, compressor will stop while indoor fan will operate; During heating operation, the complete unit will stop operation.	Refer to the malfunction analysis (IPM protection, loss of synchronism protection and overcurrent protection of phase current for compressor).	
28	Charging malfunction of capacitor	PU			During cooling and drying operation, compressor will stop while indoor fan will operate; During heating operation, the complete unit will stop	Refer to the part three—charging malfunction analysis of capacitor	
29	Malfunction of module temperature sensor circuit	P7			During cooling and drying operation, compressor will stop while indoor fan will operate; During heating operation, the complete unit will stop	Replace outdoor control panel AP1	
30	Module high temperature protection	P8			During cooling operation, compressor will stop while indoor fan will operate; During heating operation, the complete unit will stop	After the complete unit is de-energized for 20mins, check whether the thermal grease on IPM Module of outdoor control panel AP1 is sufficient and whether the radiator is inserted tightly. If its no use, please replace control panel AP1.	
31	Overload protection for compressor	H3			During cooling and drying operation, compressor will stop while indoor fan will operate; During heating operation, the complete unit will stop operation.	1. Wiring terminal OVC-COMP is loosened. In normal state, the resistance for this terminal should be less than 1ohm. 2. Refer to the malfunction analysis (discharge protection, overload)	
32	IPM protection	H5			During cooling and drying operation, compressor will stop while indoor fan will operate; During heating operation, the complete unit will stop operation.	Refer to the malfunction analysis (IPM protection, loss of synchronism protection and overcurrent protection of phase current for compressor).	
33	Malfunction of detecting plate(WIFI )	JF			Loads operate normally, while the unit can't be normally controlled by APP.	1. Main board of indoor unit is damaged; 2. Detection board is damaged; 3. The connection between indoor unit and detection board is not good;	



NO.	Malfunction Name	Display Method of Indoor Unit			A/C status	Possible Causes	
		Dual-8 Code Display	Indicator Display (during blinking, ON 0.5s and OFF 0.5s)				
			Operation Indicator	Cool Indicator			Heating Indicator
34	Internal motor (fan motor) do not operate	H6				Internal fan motor, external fan motor, compressor and electric heater stop operation, guide louver stops at present location.	<ol style="list-style-type: none"> <li>1. Bad contact of DC motor feedback terminal.</li> <li>2. Bad contact of DC motor control end.</li> <li>3. Fan motor is stalling.</li> <li>4. Motor malfunction.</li> <li>5. Malfunction of mainboard rev detecting circuit.</li> </ol>
35	Desynchronizing of compressor	H7				During cooling and drying operation, compressor will stop while indoor fan will operate; During heating operation, the complete unit will stop operation.	Refer to the malfunction analysis (IPM protection, loss of synchronism protection and overcurrent protection of phase current for compressor.
36	PFC protection	HC				During cooling and drying operation, compressor will stop while indoor fan will operate; During heating operation, the complete unit will stop operation.	Replace outdoor control panel AP1 or Reactor
37	Outdoor DC fan motor malfunction	L3				Outdoor DC fan motor malfunction lead to compressor stop operation,	DC fan motor malfunction or system blocked or the connector loosed
38	power protection	L9				compressor stop operation and Outdoor fan motor will stop 30s latter , 3 minutes latter fan motor and compressor will restart	To protect the electrical components when detect high power
39	Indoor unit and outdoor unit doesnt match	LP				compressor and Outdoor fan motor cant work	Indoor unit and outdoor unit doesnt match
40	Failure start-up	LC				During cooling and drying operation, compressor will stop while indoor fan will operate; During heating operation, the complete unit will stop operation.	Refer to the malfunction analysis
41	Defrosting	OFF 3S and blink once (during blinking, ON 10s and OFF 0.5s)				Defrosting will occur in heating mode. Compressor will operate while indoor fan will stop operation.	Its the normal state
42	Anti-freezing protection for evaporator	E2				Not the error code. It's the status code for the operation	

NO.	Malfunction Name	Display Method of Indoor Unit				A/C status	Possible Causes
		Dual-8 Code Display	Indicator Display (during blinking, ON 0.5s and OFF 0.5s)				
			Operation Indicator	Cool Indicator	Heating Indicator		
43	Malfunction of phase current detection circuit for compressor	U1				During cooling and drying operation, compressor will stop while indoor fan will operate; During heating operation, the complete unit will stop	Replace outdoor control panel AP1
44	Malfunction of voltage dropping for DC bus-bar	U3				During cooling and drying operation, compressor will stop while indoor fan will operate; During heating operation, the complete unit will stop	Supply voltage is unstable
45	Malfunction of complete units current detection	U5				During cooling and drying operation, the compressor will stop while indoor fan will operate; During heating operating, the complete unit will stop operation.	Theres circuit malfunction on outdoor units control panel AP1, please replace the outdoor units control panel AP1.
46	The four-way valve is abnormal	U7				If this malfunction occurs during heating operation, the complete unit will stop operation.	1. Supply voltage is lower than AC175V; 2. Wiring terminal 4V is loosened or broken; 3. 4V is damaged, please replace 4V.
47	Cold air prevention protection	E9				Not the error code. It's the status code for the operation	
48	Refrigerant recovery mode	Fo				Refrigerant recovery. The Serviceman operates it for maintenance	
49	Undefined outdoor unit error	oE				Cool: compressor and outdoor fan stops operation, while indoor fan operates; Heat: compressor, outdoor fan and indoor fan stop operation.	1. Outdoor ambient temperature exceeds the operation range of unit (eg: less than -20oC or more than 60oC for cooling; more than 30oC for heating); 2. Failure startup of compressor? 3. Are wires of compressor not connected tightly? 4. Is compressor damaged? 5. Is main board damaged?
50	Malfunction of zero-cross detection circuit	U8				The complete unit stops	1. Power supply is abnormal; 2. Detection circuit of indoor control mainboard is abnormal.

**Analysis or processing of some of the malfunction display:****1. Compressor discharge protection**

Possible causes: shortage of refrigerant; blockage of air filter; poor ventilation or air flow short pass for condenser; the system has noncondensing gas (such as air, water etc.); blockage of capillary assy (including filter); leakage inside four-way valve causes incorrect operation; malfunction of compressor; malfunction of protection relay; malfunction of discharge sensor; outdoor temperature too high.

Processing method: refer to the malfunction analysis in the above section.

**2. Low voltage overcurrent protection**

Possible cause: Sudden drop of supply voltage.

**3. Communication malfunction**

Processing method: Check if communication signal cable is connected reliably.

**4. Sensor open or short circuit**

Processing method: Check whether sensor is normal, connected with the corresponding position on the controller and if damage of lead wire is found.

**5. Compressor over load protection**

Possible causes: insufficient or too much refrigerant; blockage of capillary and increase of suction temp.; improper running of compressor, burning in or stuck of bearing, damage of discharge valve; malfunction of protector.

Processing method: adjust refrigerant amount; replace the capillary; replace the compressor; use universal meter to check if the contactor of compressor is fine when it is not overheated, if not replace the protector.

**6. System malfunction**

i.e. overload protection. When tube temperature (Check the temperature of outdoor heat exchanger when cooling and check the temperature of indoor heat exchanger when heating) is too high, protection will be activated.

Possible causes: Outdoor temperature is too high when cooling; insufficient outdoor air circulation; refrigerant flow malfunction.

please refer to the malfunction analysis in the previous section for handling method .

**7. IPM module protection**

Processing method: Once the module malfunction happens, if it persists for a long time and can not be self-canceled, cut off the power and turn off the unit, and then re-energize the unit again after about 10 min. After repeating the procedure for several times, if the malfunction still exists, replace the module.

## 9.2 Troubleshooting for Main Malfunction

● Indoor unit:

### 1. Malfunction of Temperature Sensor F1, F2

Main detection points:

- Is the wiring terminal between the temperature sensor and the controller loosened or poorly contacted?
- Is there short circuit due to trip-over of the parts?
- Is the temperature sensor broken?
- Is mainboard broken?

Malfunction diagnosis process:

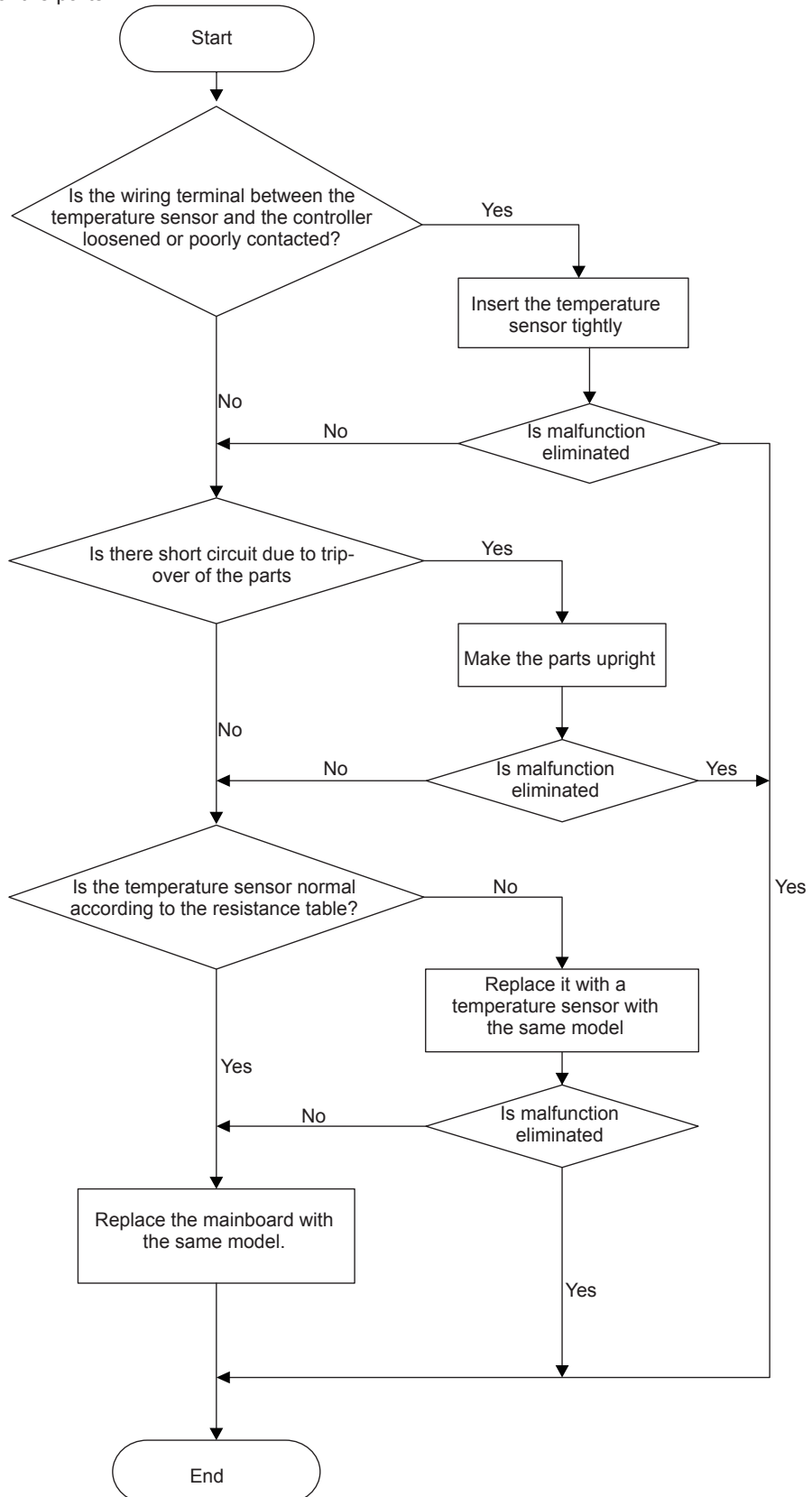

## 2. Malfunction of Blocked Protection of IDU Fan Motor H6

Main detection points:

- Smoothly Is the control terminal of PG motor connected tightly?
- Smoothly Is the feedback interface of PG motor connected tightly?
- The fan motor cant operate?
- The motor is broken?
- Detection circuit of the mainboard is defined abnormal?

Malfunction diagnosis process:

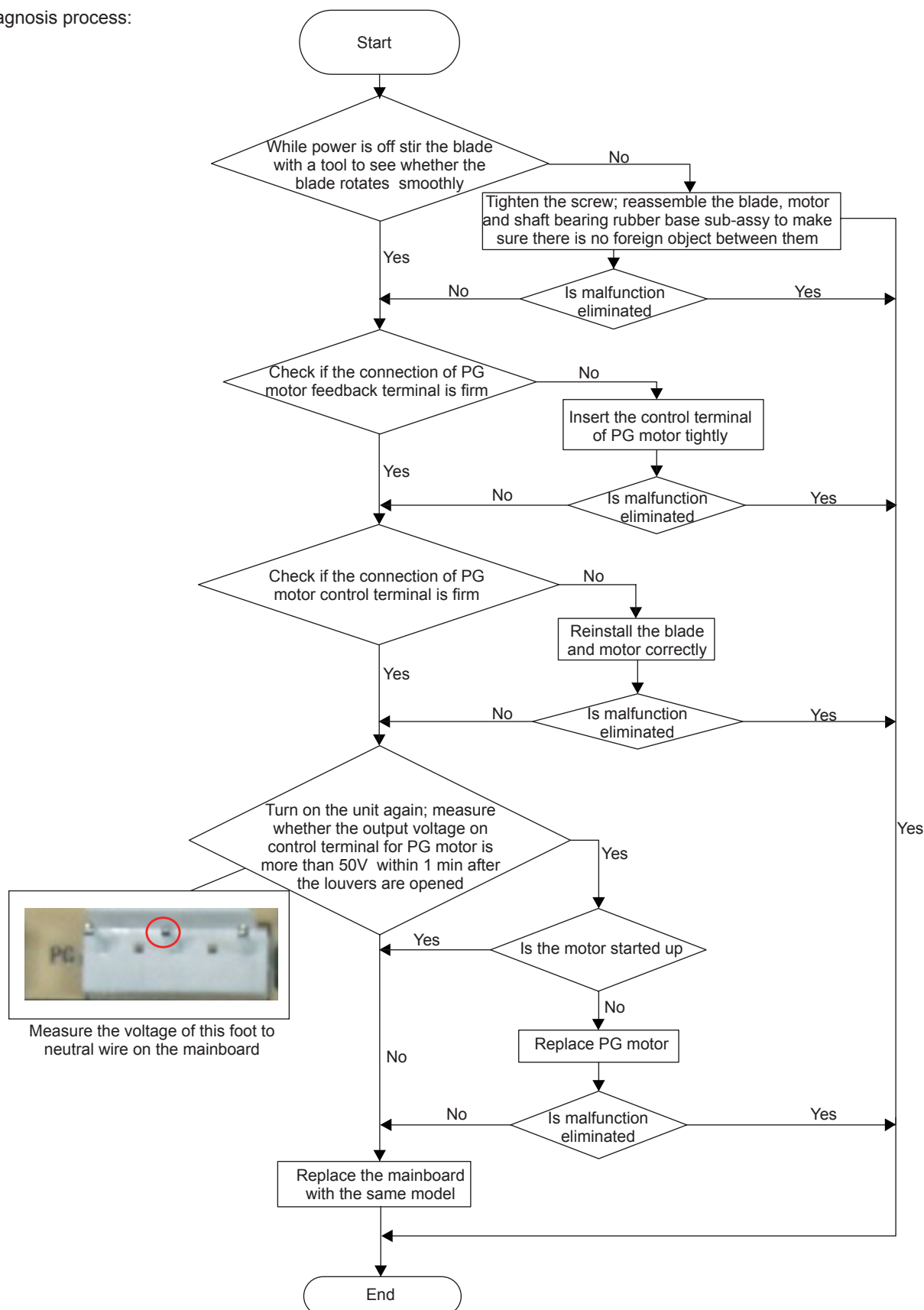

### 3. Malfunction of Protection of Jumper Cap C5

Main detection points:

- Is there jumper cap on the mainboard?
- Is the jumper cap inserted correctly and tightly?
- The jumper is broken?
- The motor is broken?
- Detection circuit of the mainboard is defined abnormal?

Malfunction diagnosis process:

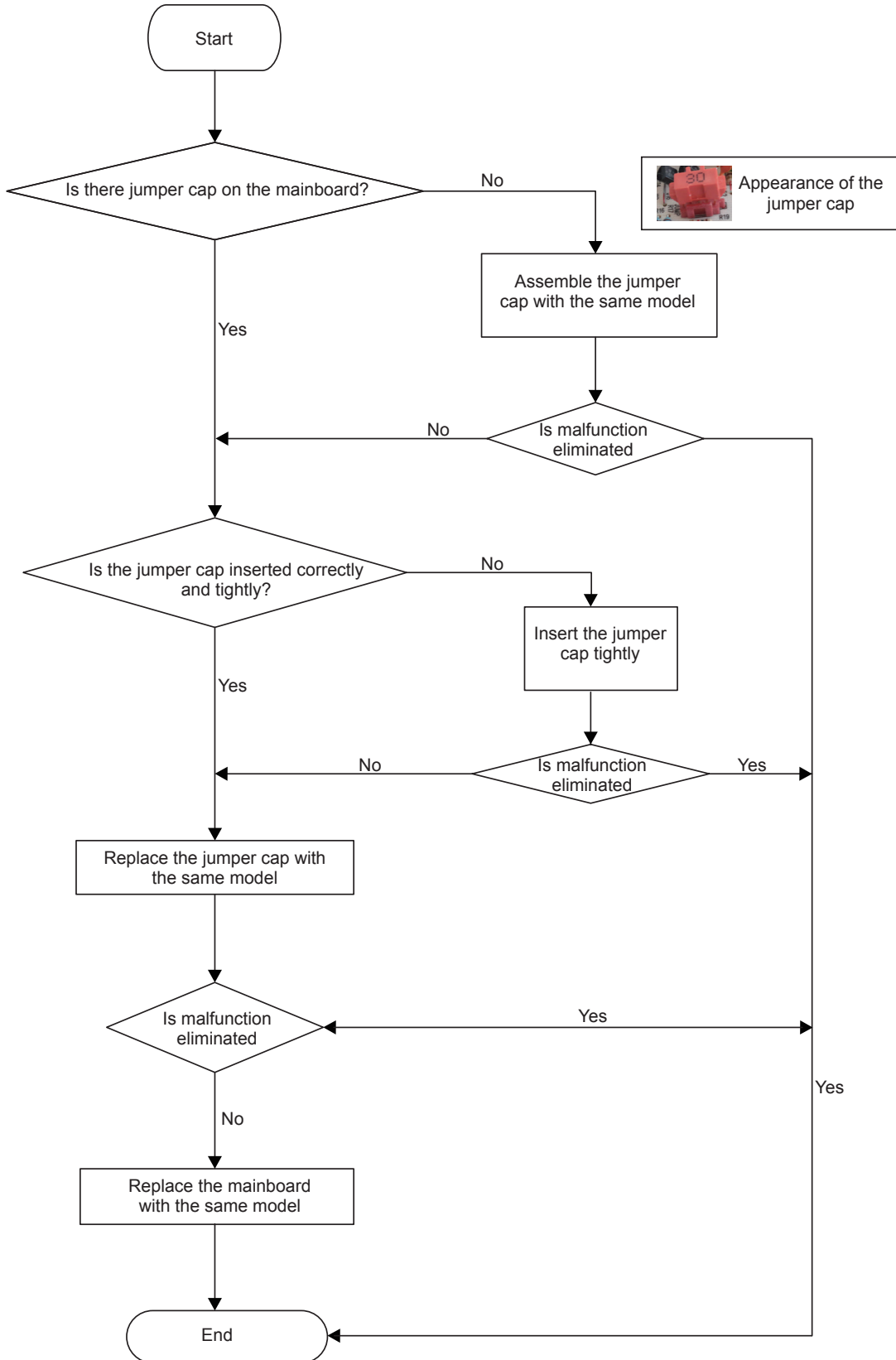

#### 4. Malfunction of Zero-crossing Inspection Circuit Malfunction of the IDU Fan Motor U8

Main detection points:

- Instant energization after de-energization while the capacitor discharges slowly?
- The zero-cross detection circuit of the mainboard is defined abnormal?

Malfunction diagnosis process:

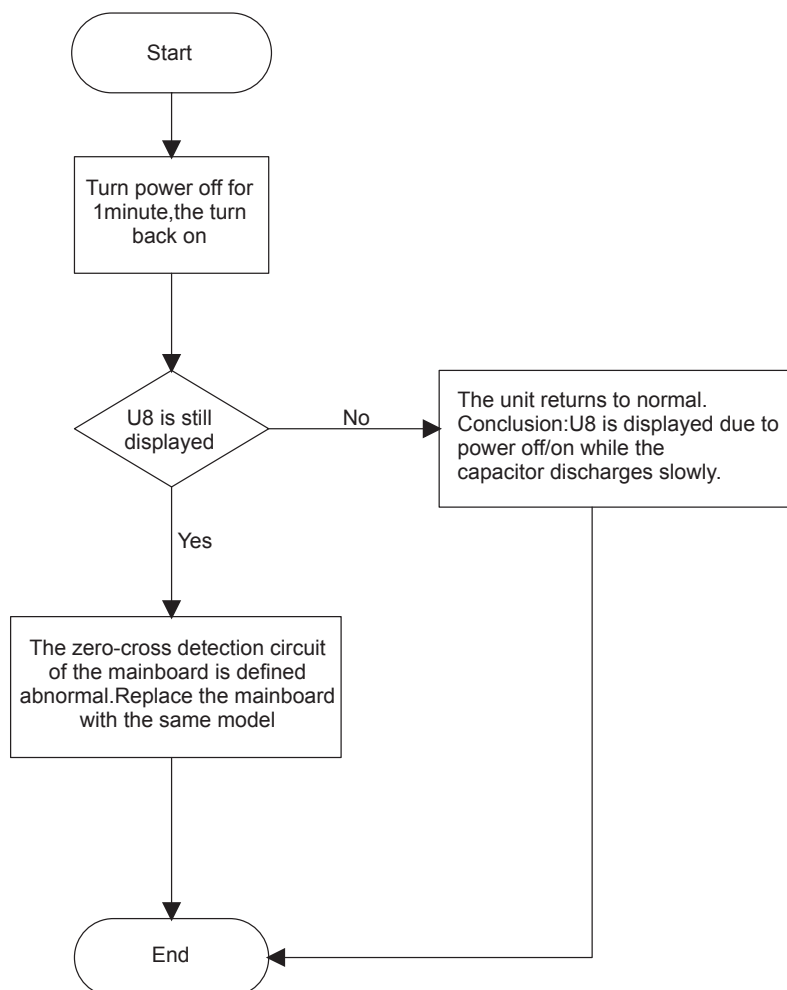

5. Malfunction of detecting plate(WIFI) JF

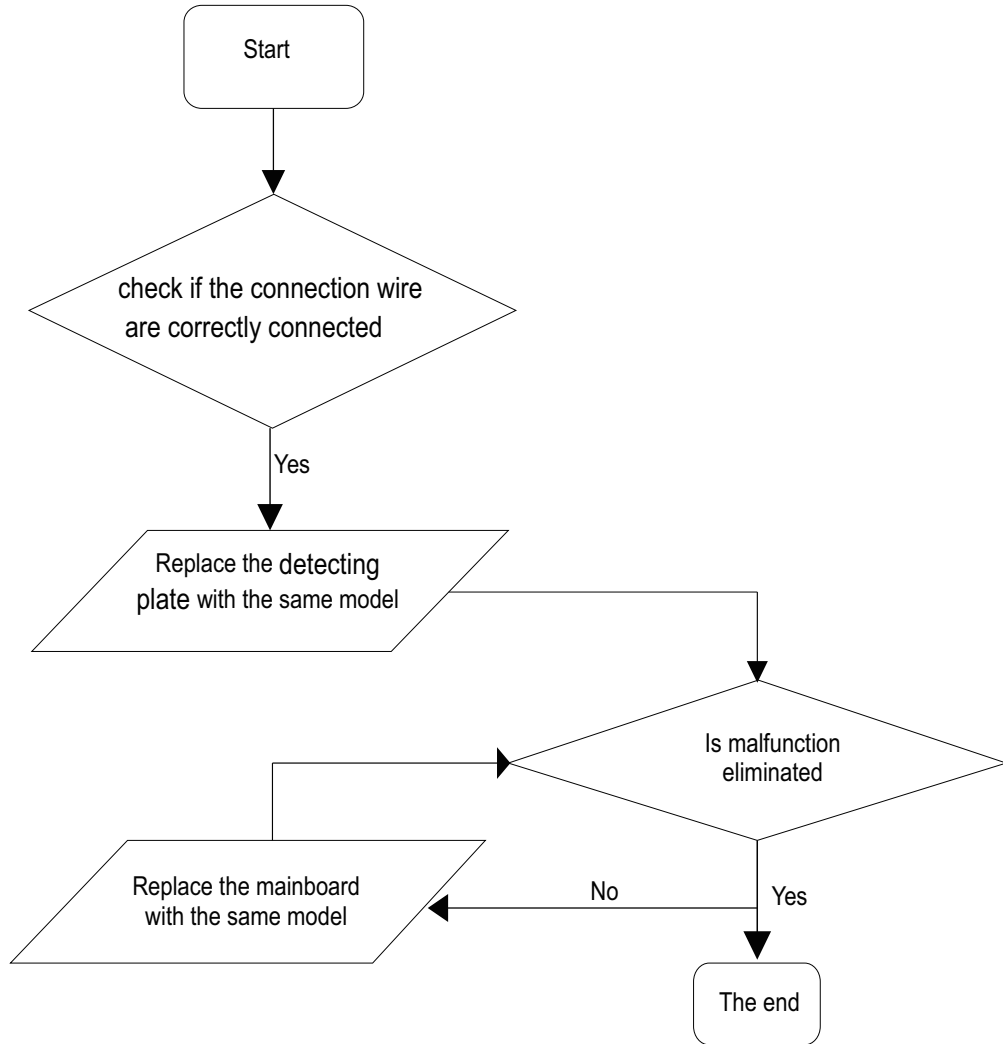



6. Malfunction of Insufficient fluorine protection F0

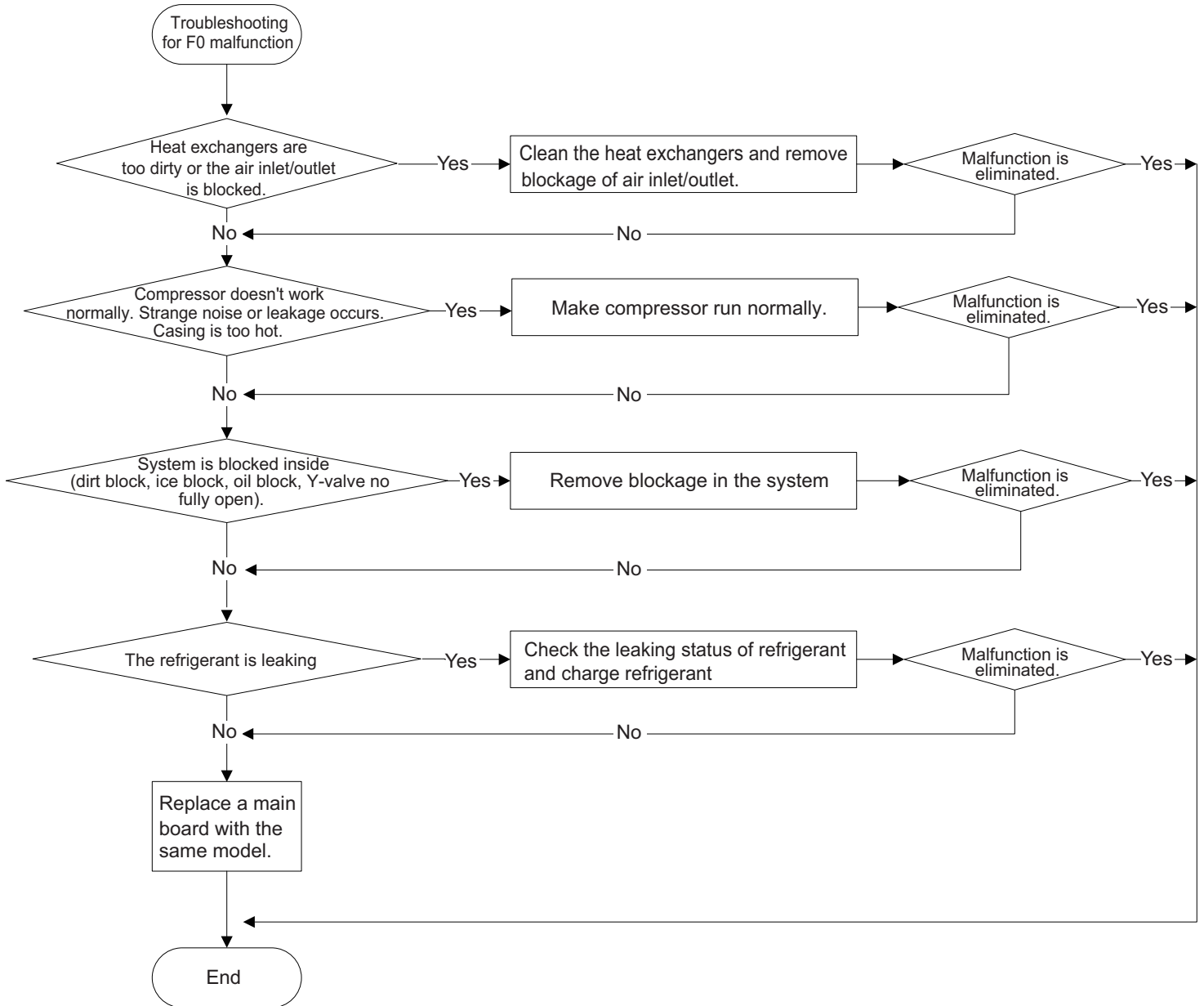

●Outdoor unit:

**(1) Capacitor charge fault (Fault with outdoor unit) (AP1 below refers to the outdoor control panel)**

Main Check Points:

- Use AC voltmeter to check if the voltage between terminal L and N on the wiring board is within 210VAC~240VAC.
- Is the reactor (L) correctly connected? Is the connection loose or fallen? Is the reactor (L) damaged?

Fault diagnosis process:

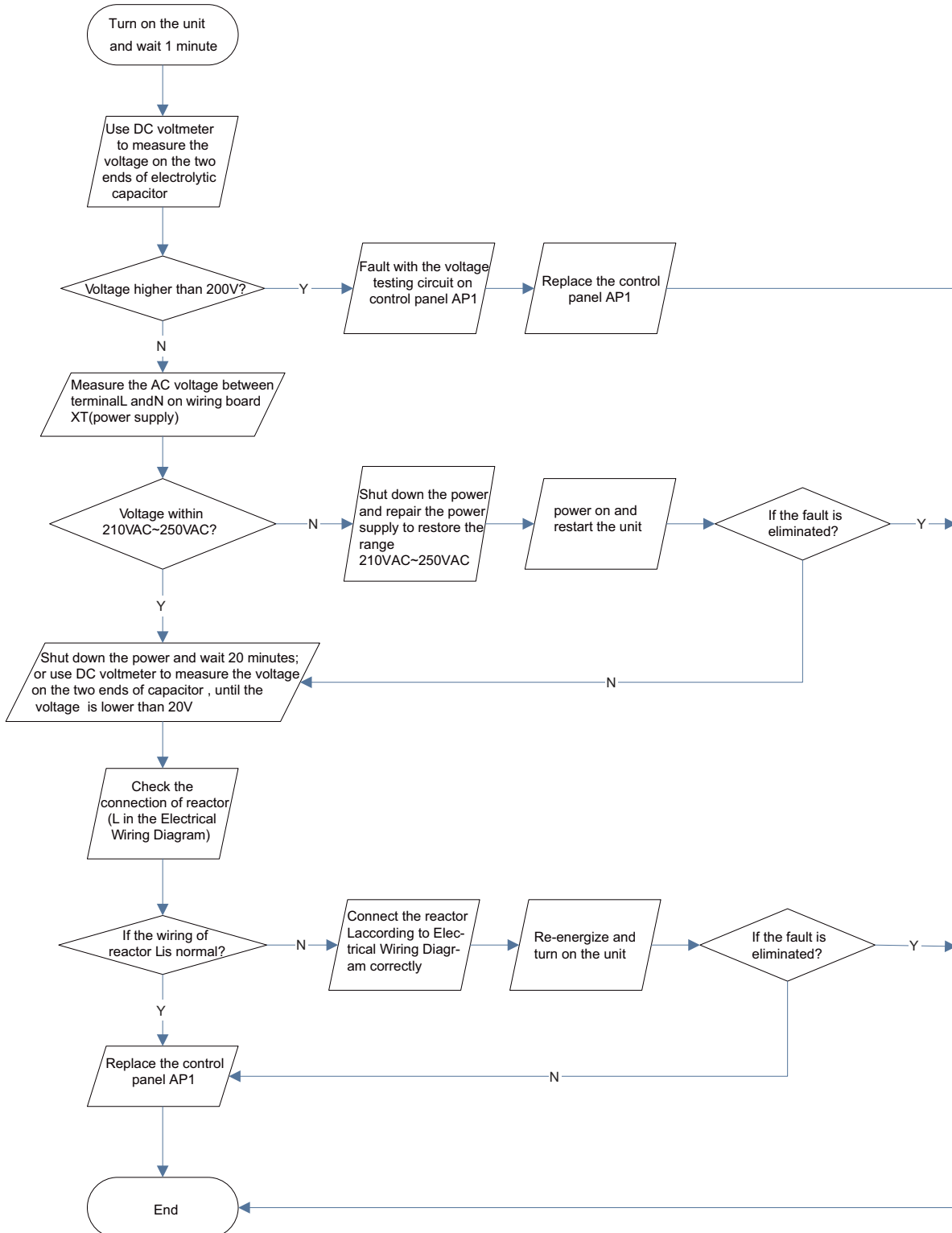

**(2) IPM protection, phase current overcurrent (the control board as below indicates the control board of outdoor unit) H5/P5**

Mainly detect:

- (1) Compressor COMP terminal (2) voltage of power supply (3) compressor
- (4) Refrigerant-charging volume (5) air outlet and air inlet of outdoor/indoor unit

Troubleshooting:

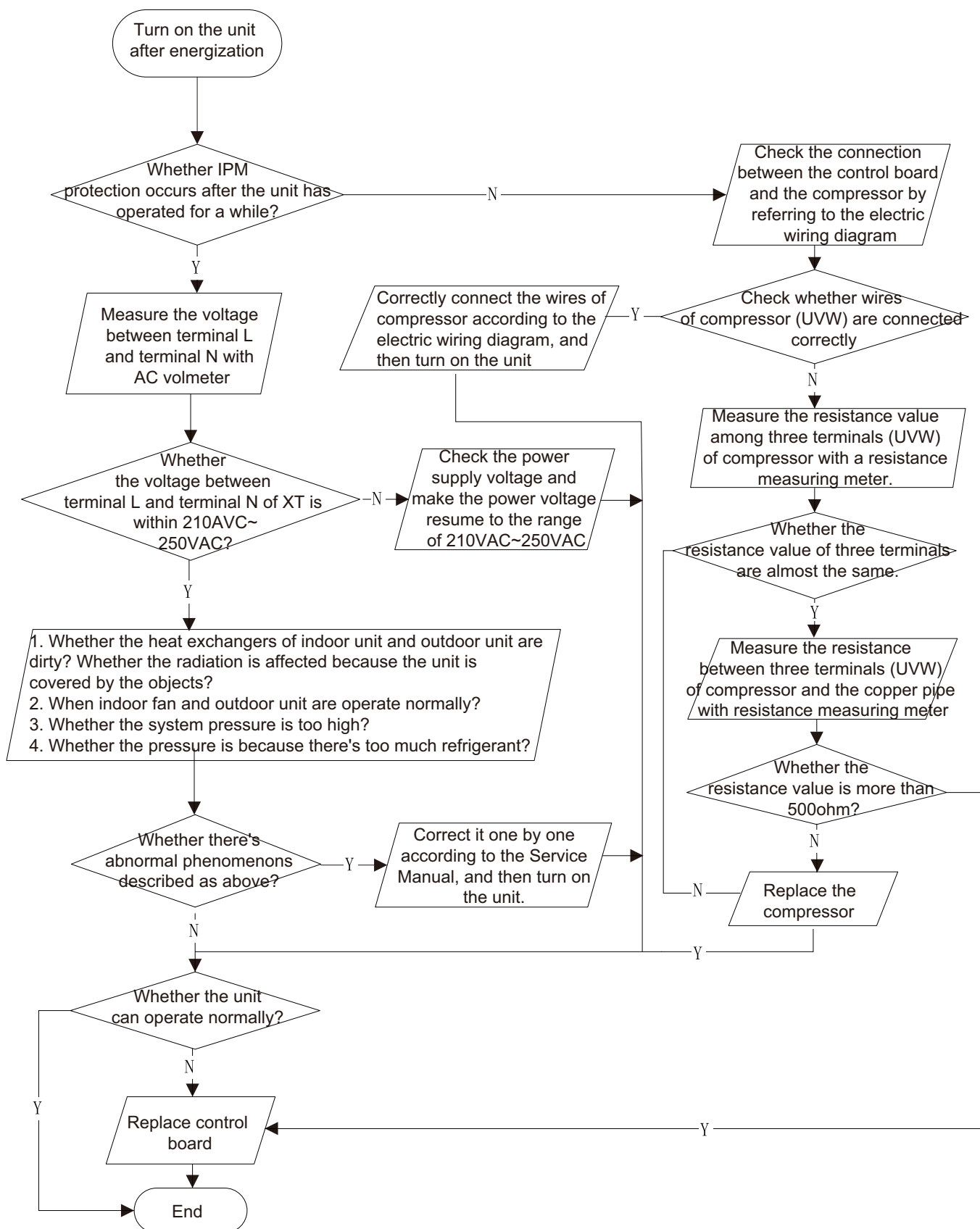

### (3) High temperature and overload protection diagnosis (AP1 hereinafter refers to the control board of the outdoor unit)

Mainly detect:

- Is outdoor ambient temperature in normal range?
- Are the outdoor and indoor fans operating normally?
- Is the heat dissipation environment inside and outside the unit good?

Fault diagnosis process:

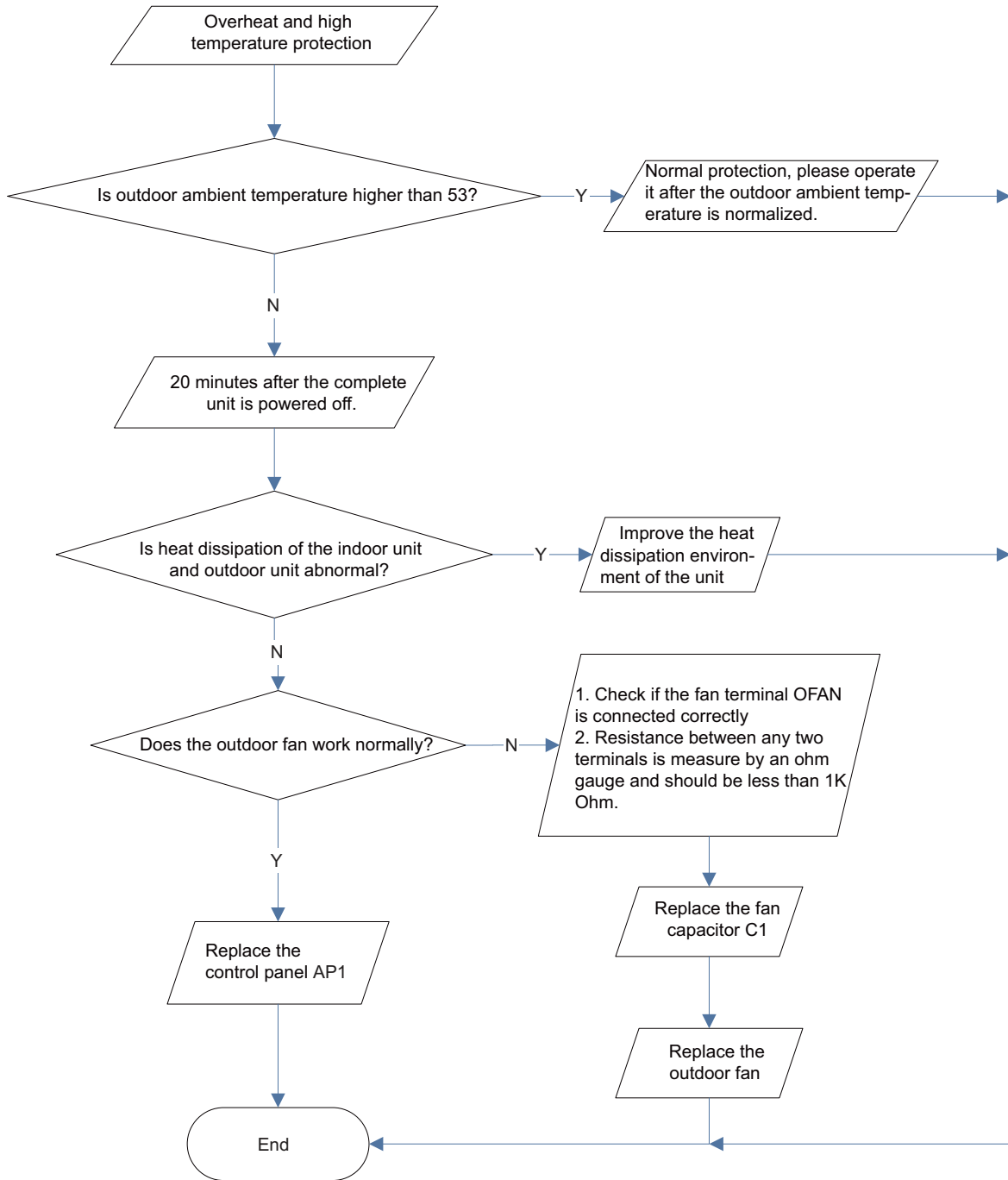

**(4) Start-up failure (following AP1 for outdoor unit control board)**

Mainly detect:

- Whether the compressor wiring is connected correct?
- Is compressor broken?
- Is time for compressor stopping enough?

Fault diagnosis process:

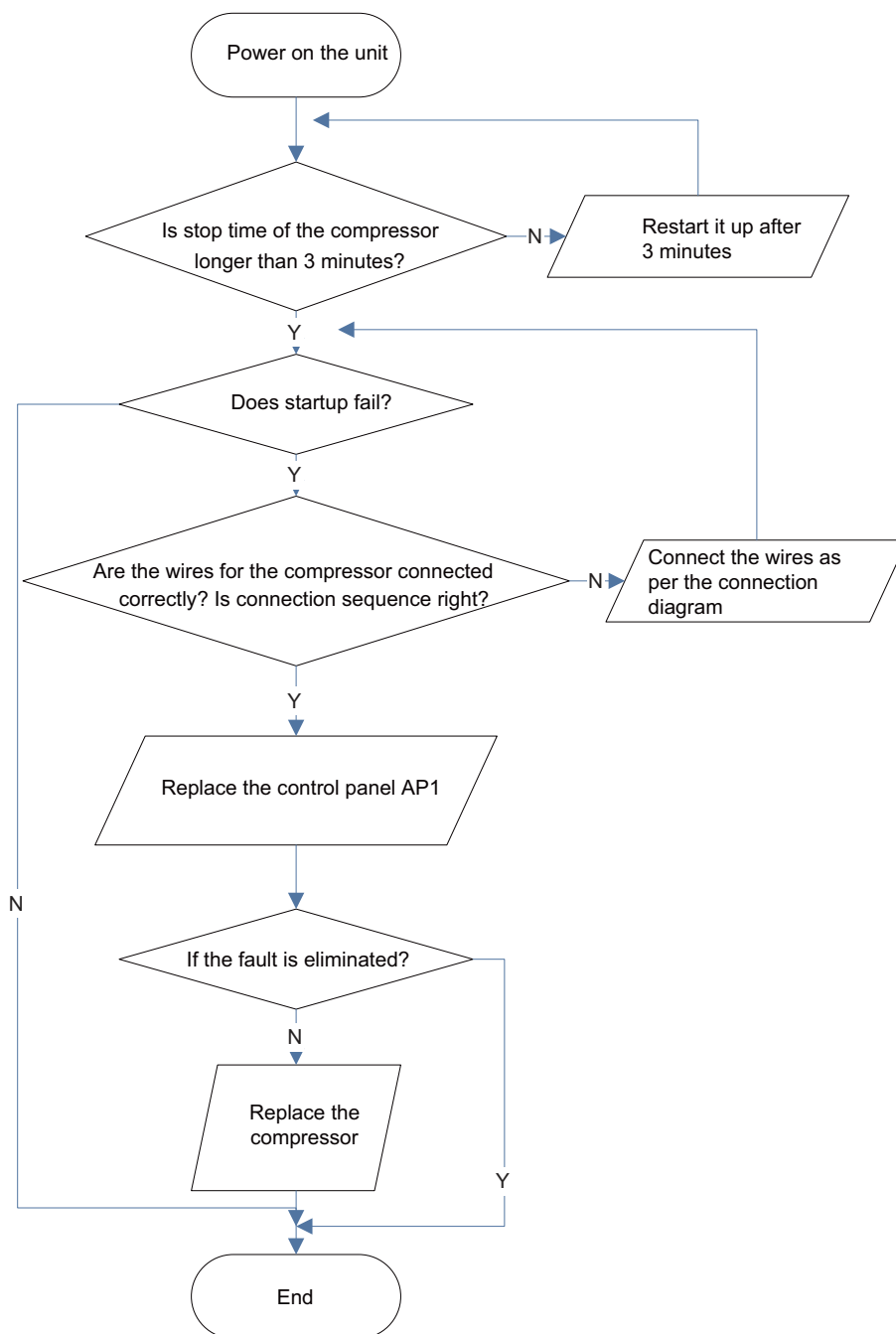

**(5) Out of step diagnosis for the compressor (AP1 hereinafter refers to the control board of the outdoor unit)**

Mainly detect:

- Is the system pressure too high?
- Is the input voltage too low?

Fault diagnosis process:

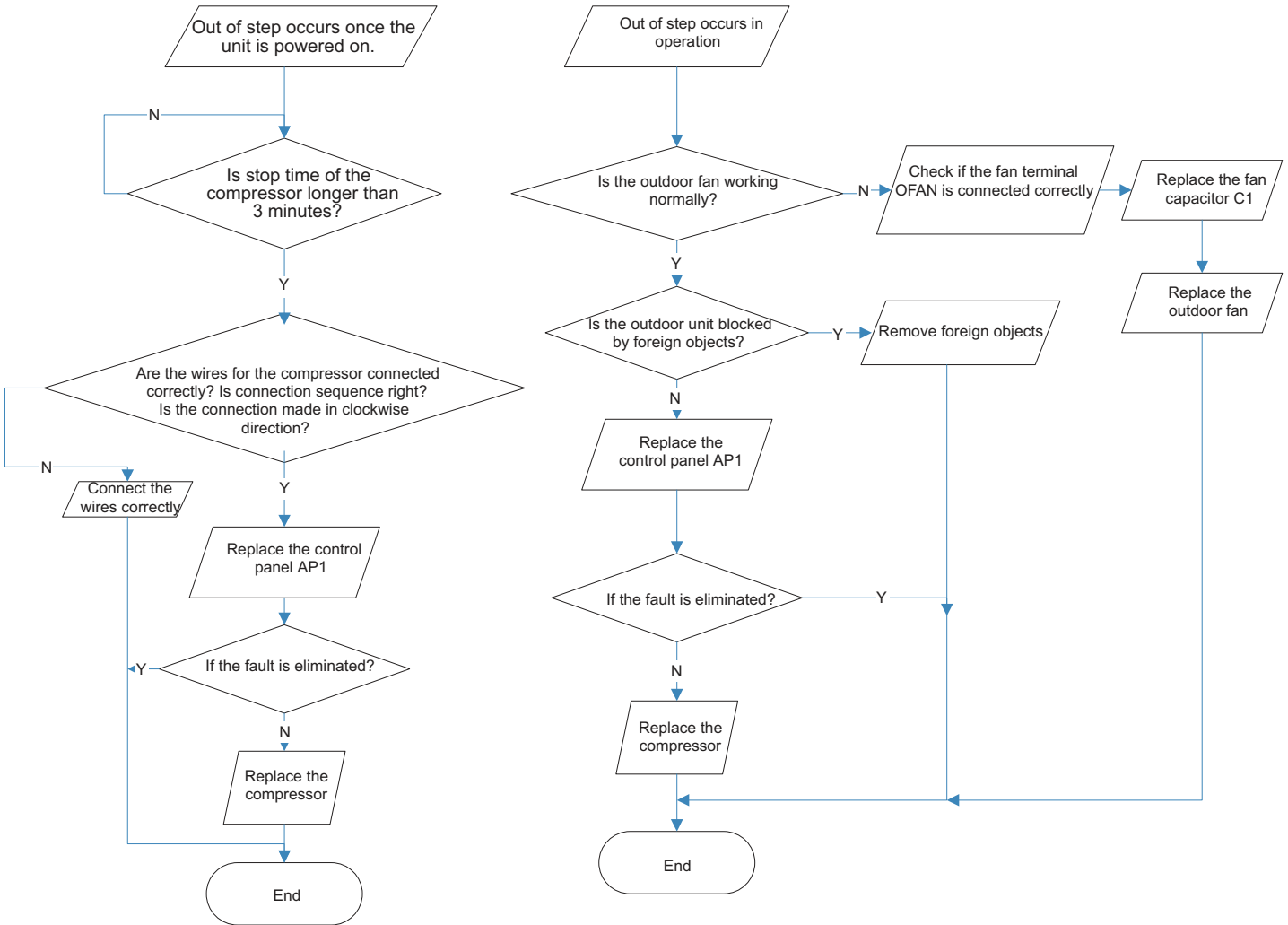

**(6) Overload and air exhaust malfunction diagnosis (following AP1 for outdoor unit control board)**

Mainly detect:

- Is the PMV connected well or not? Is PMV damaged?
- Is refrigerant leaked?

Fault diagnosis process:

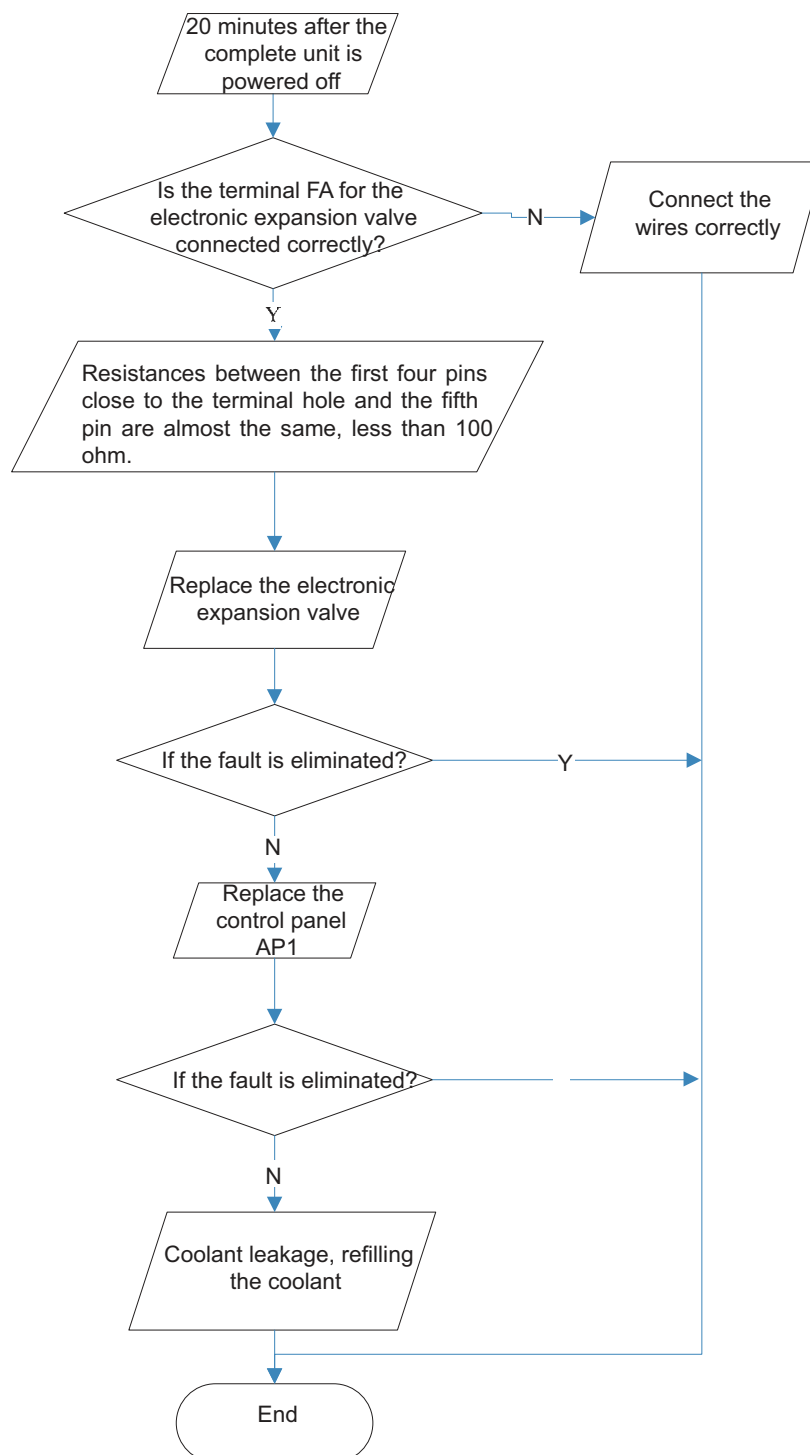

**(7) Communication malfunction: (following AP1 for outdoor unit control board)**

Mainly detect:

- Is there any damage for the indoor unit mainboard communication circuit? Is communication circuit damaged?
- Detect the indoor and outdoor units connection wire and indoor and outdoor units inside wiring is connect well or not, if is there any damage?

Fault diagnosis process:

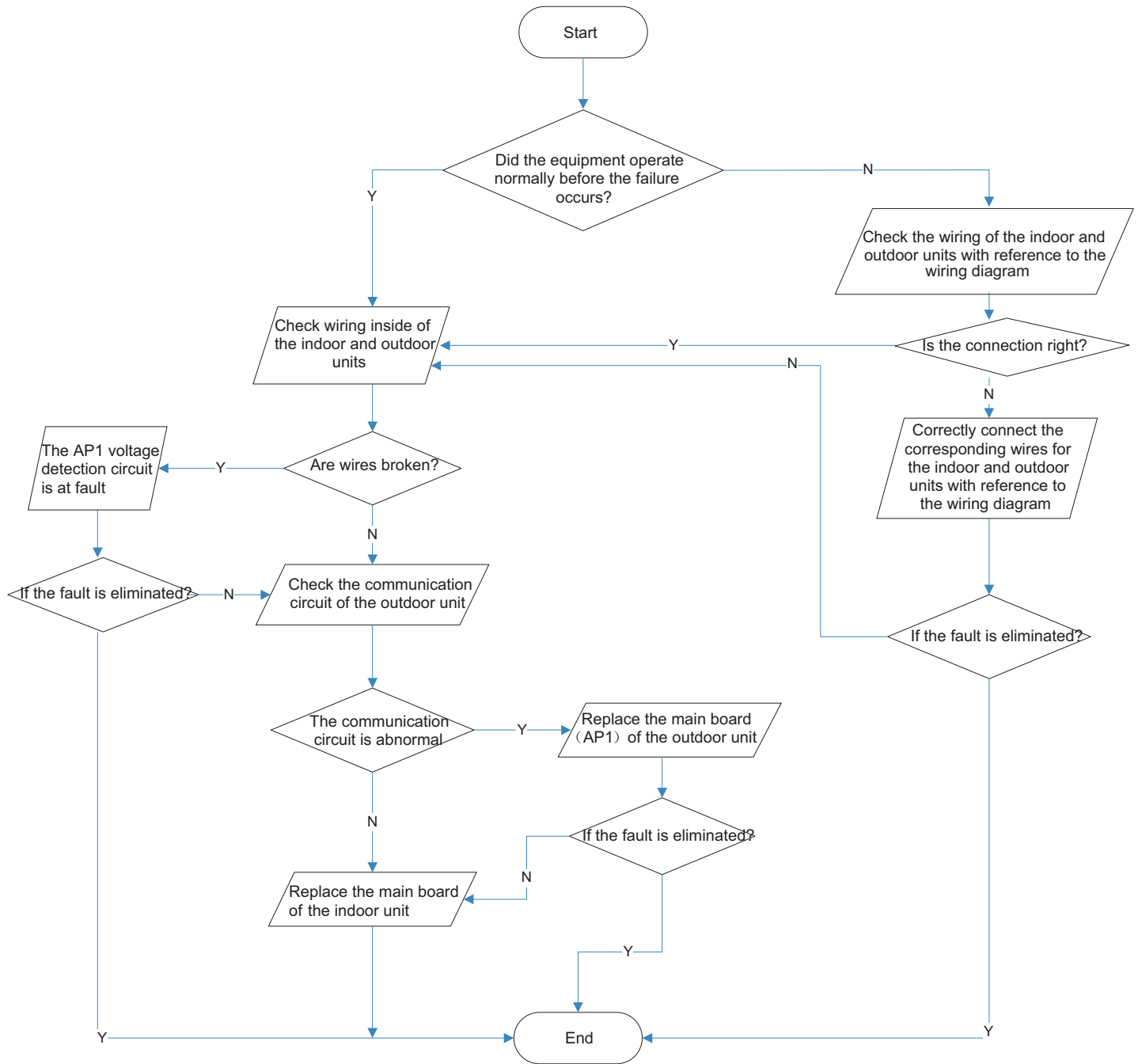



## 9.3 Troubleshooting for Normal Malfunction

### 1. Air Conditioner Cant be Started Up

Possible Causes	Discriminating Method (Air conditioner Status)	Troubleshooting
No power supply, or poor connection for power plug	After energization, operation indicator isnt bright and the buzzer cant give out sound	Confirm whether its due to power failure. If yes, wait for power recovery. If not, check power supply circuit and make sure the power plug is connected well.
Wrong wire connection between indoor unit and outdoor unit, or poor connection for wiring terminals	Under normal power supply circumstances, operation indicator isnt bright after energization	Check the circuit according to circuit diagram and connect wires correctly. Make sure all wiring terminals are connected firmly
Electric leakage for air conditioner	After energization, room circuit breaker trips off at once	Make sure the air conditioner is grounded reliably Make sure wires of air conditioner is connected correctly Check the wiring inside air conditioner. Check whether the insulation layer of power cord is damaged; if yes, place the power cord.
Model selection for air switch is improper	After energization, air switch trips off	Select proper air switch
Malfunction of remote controller	After energization, operation indicator is bright, while no display on remote controller or buttons have no action.	Replace batteries for remote controller Repair or replace remote controller

### 2. Poor Cooling (Heating) for Air Conditioner

Possible Causes	Discriminating Method (Air conditioner Status)	Troubleshooting
Set temperature is improper	Observe the set temperature on remote controller	Adjust the set temperature
Rotation speed of the IDU fan motor is set too low	Small wind blow	Set the fan speed at high or medium
Filter of indoor unit is blocked	Check the filter to see its blocked	Clean the filter
Installation position for indoor unit and outdoor unit is improper	Check whether the installation position is proper according to installation requirement for air conditioner	Adjust the installation position, and install the rainproof and sunproof for outdoor unit
Refrigerant is leaking	Discharged air temperature during cooling is higher than normal discharged wind temperature; Discharged air temperature during heating is lower than normal discharged wind temperature; Units pressure is much lower than regulated range	Find out the leakage causes and deal with it. Add refrigerant.
Malfunction of 4-way valve	Blow cold wind during heating	Replace the 4-way valve
Malfunction of capillary	Discharged air temperature during cooling is higher than normal discharged wind temperature; Discharged air temperature during heating is lower than normal discharged wind temperature; Unit pressure is much lower than regulated range. If refrigerant isnt leaking, part of capillary is blocked	Replace the capillary
Flow volume of valve is insufficient	The pressure of valves is much lower than that stated in the specification	Open the valve completely
Malfunction of horizontal louver	Horizontal louver cant swing	Refer to point 3 of maintenance method for details
Malfunction of the IDU fan motor	The IDU fan motor cant operate	Refer to troubleshooting for H6 for maintenance method in details
Malfunction of the ODU fan motor	The ODU fan motor cant operate	Refer to point 4 of maintenance method for details
Malfunction of compressor	Compressor cant operate	Refer to point 5 of maintenance method for details

### 3. Horizontal Louver Cant Swing

Possible Causes	Discriminating Method (Air conditioner Status)	Troubleshooting
Wrong wire connection, or poor connection	Check the wiring status according to circuit diagram	Connect wires according to wiring diagram to make sure all wiring terminals are connected firmly
Stepping motor is damaged	Stepping motor cant operate	Repair or replace stepping motor
Main board is damaged	Others are all normal, while horizontal louver cant operate	Replace the main board with the same model

**4. ODU Fan Motor Cant Operate**

Possible causes	Discriminating method (air conditioner status)	Troubleshooting
Wrong wire connection, or poor connection	Check the wiring status according to circuit diagram	Connect wires according to wiring diagram to make sure all wiring terminals are connected firmly
Capacity of the ODU fan motor is damaged	Measure the capacity of fan capacitor with an universal meter and find that the capacity is out of the deviation range indicated on the nameplate of fan capacitor.	Replace the capacity of fan
Power voltage is a little low or high	Use universal meter to measure the power supply voltage. The voltage is a little high or low	Suggest to equip with voltage regulator
Motor of outdoor unit is damaged	When unit is on, cooling/heating performance is bad and ODU compressor generates a lot of noise and heat.	Change compressor oil and refrigerant. If no better, replace the compressor with a new one

**5. Compressor Cant Operate**

Possible causes	Discriminating method (air conditioner status)	Troubleshooting
Wrong wire connection, or poor connection	Check the wiring status according to circuit diagram	Connect wires according to wiring diagram to make sure all wiring terminals are connected firmly
Capacity of compressor is damaged	Measure the capacity of fan capacitor with an universal meter and find that the capacity is out of the deviation range indicated on the nameplate of fan capacitor.	Replace the compressor capacitor
Power voltage is a little low or high	Use universal meter to measure the power supply voltage. The voltage is a little high or low	Suggest to equip with voltage regulator
Coil of compressor is burnt out	Use universal meter to measure the resistance between compressor terminals and its 0	Repair or replace compressor
Cylinder of compressor is blocked	Compressor cant operate	Repair or replace compressor

**6. Air Conditioner is Leaking**

Possible causes	Discriminating method (air conditioner status)	Troubleshooting
Drain pipe is blocked	Water leaking from indoor unit	Eliminate the foreign objects inside the drain pipe
Drain pipe is broken	Water leaking from drain pipe	Replace drain pipe
Wrapping is not tight	Water leaking from the pipe connection place of indoor unit	Wrap it again and bundle it tightly

**7. Abnormal Sound and Vibration**

Possible causes	Discriminating method (air conditioner status)	Troubleshooting
When turn on or turn off the unit, the panel and other parts will expand and theres abnormal sound	Theres the sound of "PAPA"	Normal phenomenon. Abnormal sound will disappear after a few minutes.
When turn on or turn off the unit, theres abnormal sound due to flow of refrigerant inside air conditioner	Water-running sound can be heard	Normal phenomenon. Abnormal sound will disappear after a few minutes.
Foreign objects inside the indoor unit or therere parts touching together inside the indoor unit	Theres abnormal sound fro indoor unit	Remove foreign objects. Adjust all parts position of indoor unit, tighten screws and stick damping plaster between connected parts
Foreign objects inside the outdoor unit or therere parts touching together inside the outdoor unit	Theres abnormal sound fro outdoor unit	Remove foreign objects. Adjust all parts position of outdoor unit, tighten screws and stick damping plaster between connected parts
Short circuit inside the magnetic coil	During heating, the way valve has abnormal electromagnetic sound	Replace magnetic coil
Abnormal shake of compressor	Outdoor unit gives out abnormal sound	Adjust the support foot mat of compressor, tighten the bolts
Abnormal sound inside the compressor	Abnormal sound inside the compressor	If add too much refrigerant during maintenance, please reduce refrigerant properly. Replace compressor for other circumstances.



# 10. Exploded View and Parts List

## 10.1 Indoor Unit

TW09HQ3C2DI TW12HQ3C2DI

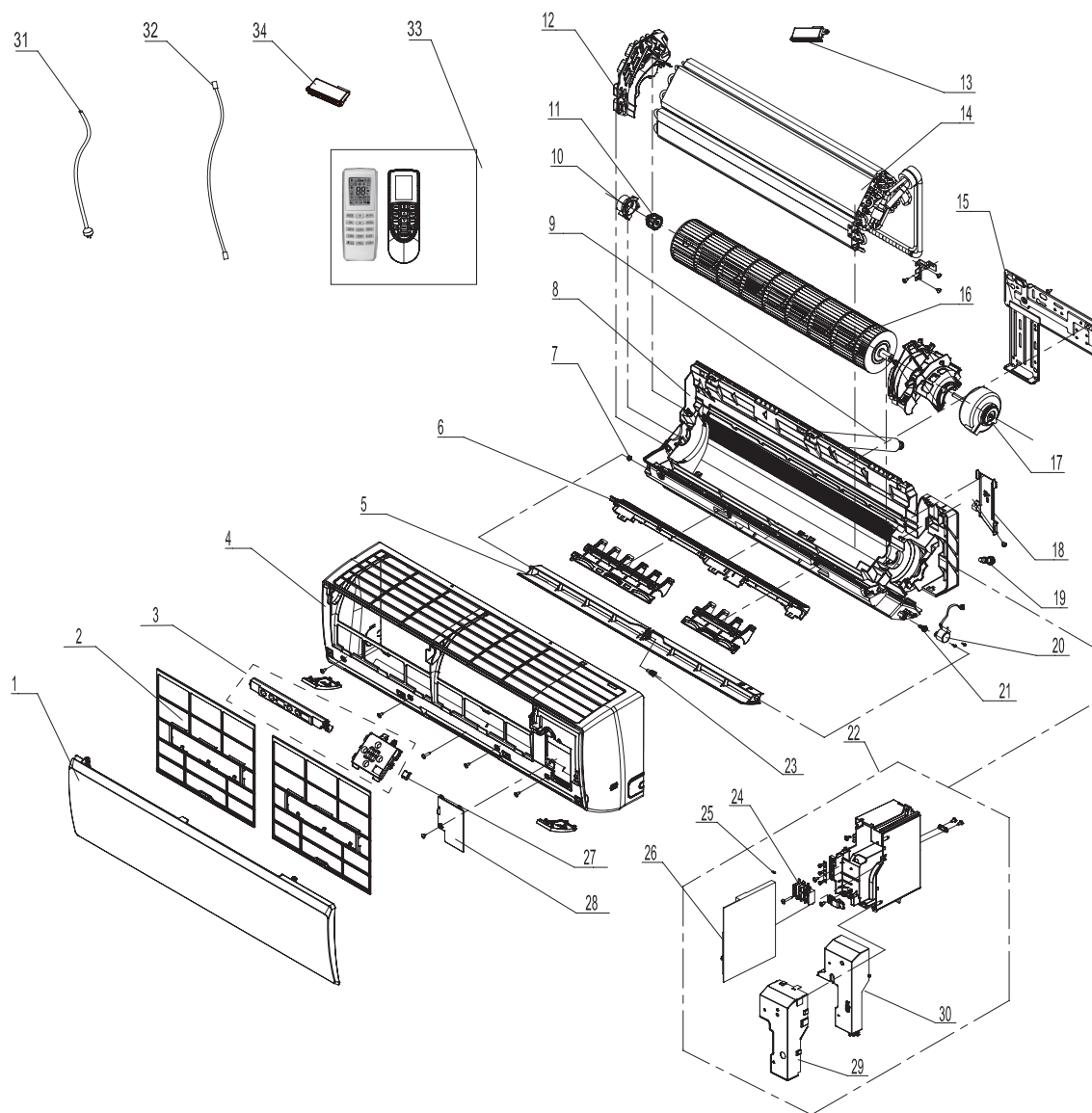

The component picture is only for reference; please refer to the actual product.

NO.	Description	Part Code		Qty
		TW09HQ3C2DI	TW12HQ3C2DI	
		Product Code	Product Code	
		CB439N11200_X40891	CB439N11300_X40891	
1	Front Panel	20000300068S	20000300069S	1
2	Filter Sub-Assy	11122219	11122468	2
3	Display Board	30565281	30565281	1
4	Front Case Assy	00000200040	00000200045	1
5	Guide Louver	1051276301	1051293101	1
6	Helicoid Tongue	26112508	26112436	1
7	Left Axile Bush	10512037	10512037	1
8	Rear Case assy	00000100066	00000100093	1
9	Drainage Hose	0523001408	05230014	1
10	Ring of Bearing	26152022	26152022	1
11	O-Gasket sub-assy of Bearing	7651205102	7651205102	1
12	Evaporator Supper	24212180	24212179	1
13	Cold Plasma Generator	/	/	/
14	Evaporator Assy	0100200004407	0100297601	1
15	Wall Mounting Frame	01252043	01252484	1
16	Cross Flow Fan	10352059	10352056	1
17	Fan Motor	1501208905	1501214604	1
18	Connecting pipe clamp	2611216401	2611216401	1
19	Rubber Plug (Water Tray)	76712012	76712012	1
20	Stepping Motor	1521212901	1521210710	1
21	Crank	73012005	73012005	1
22	Electric Box Assy	10000204154	100002003796	1
23	Axile Bush	10542036	10542036	1
24	Terminal Board	42011233	42011233	1
25	Jumper	4202021911	4202021917	1
26	Main Board	300002000309	300002000315	1
27	Screw Cover	2425203001	2425203001	1
28	Electric Box Cover Sub-Assy	0140206501	0140206501	1
29	Shield Cover of Electric Box Cover	01592150	01592150	1
30	Electric Box Cover	2011220701	2011220701	1
31	Power Cord	/	/	/
32	Connecting Cable	/	/	/
33	Remote Controller	305001000085	305001000085	1
34	Detecting plate(WIFI)	30070079	30070077	1

Above data is subject to change without notice.

## 10.2 Outdoor Unit

TW09HQ3C2DO TW12HQ3C2DO

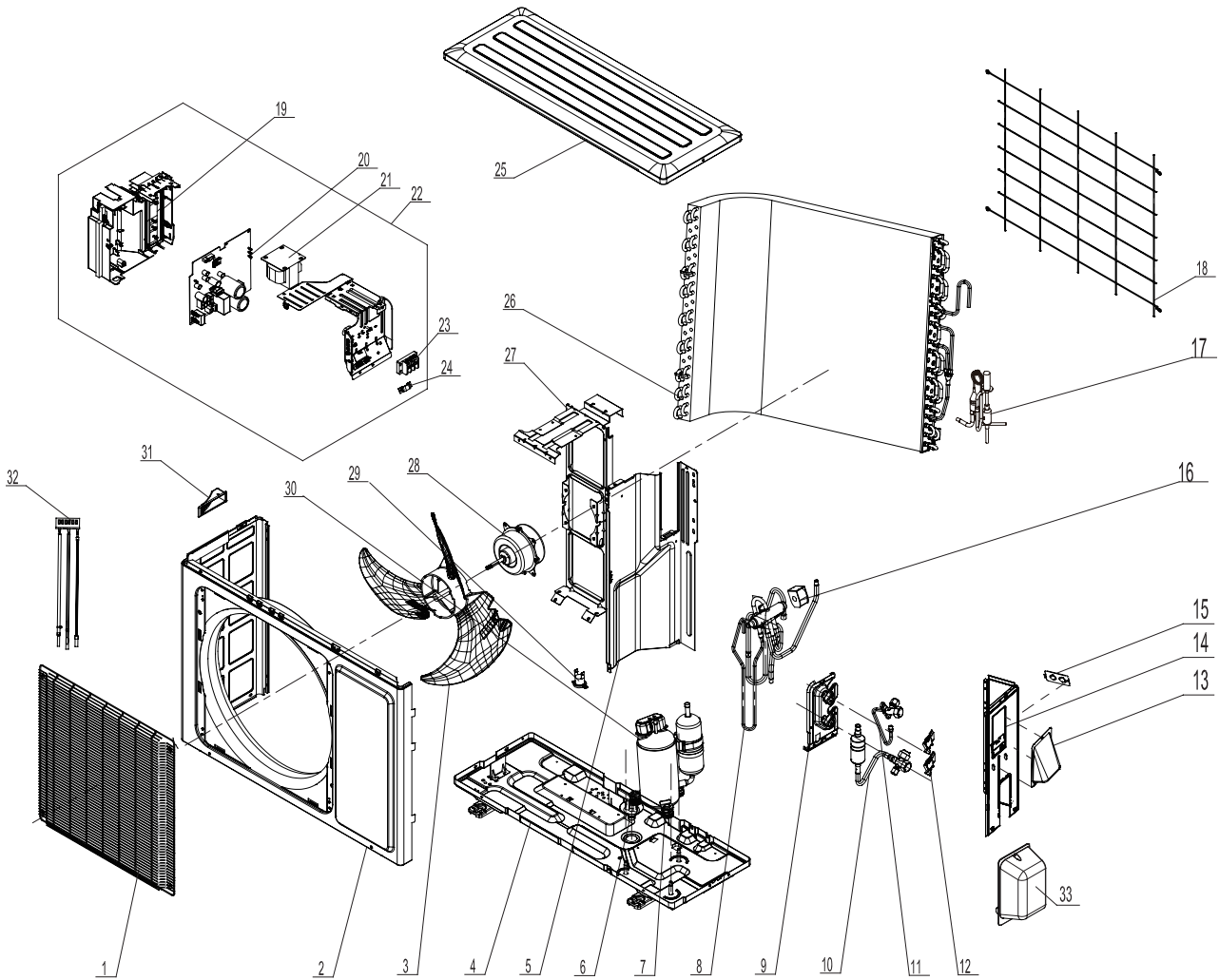

The component picture is only for reference; please refer to the actual product.

NO.	Description	Part Code		Qty
		TW09HQ3C2DO	TW12HQ3C2DO	
		Product Code CB425W08500_X40891	CB425W08100_X40891	
1	Front Grill	01473012	01473012	1
2	Front Panel Assy	0153304804	0153304804	1
3	Axial Flow Fan	10333004	10333004	1
4	Chassis Sub-assy	017000000133P	017000000126	1
5	Clapboard Sub-Assy	0123338502	0123338502	1
6	Drainage Connector	06123401	06123401	1
7	Compressor Gasket	76710287	76710287	3
8	4-Way Valve Assy	030152000171	030152000094	1
9	Valve Support	0171314201P	0171314201P	1
10	Cut off Valve Assy	07133474	07133474	1
11	Valve	07100003	07133082	1
12	Valve Support Block	26113017	26113017	2
13	Cover of Pass Wire	01413069	01413069	1
14	Right Side Plate Assy	013030713	013030713	1
15	Cable Cross Plate 2	02123014P	02123014P	1
16	Magnet Coil	4300040050	4300040050	1
17	Electric Expansion Valve Sub-Assy	030026000197	030026000192	1
18	Rear Grill	01473009	01473009	1
19	Electric Box	20113032	20113034	1
20	Main Board	300027000355	300027000359	1
21	Reactor	43130184	43130184	1
22	Electric Box Assy	100002001956	100002001959	1
23	Terminal Board	42010313	42010313	1
24	Wire Clamp	71010003	71010003	1
25	Top Cover Sub-Assy	01253073	01253073	1
26	Condenser Assy	011002000508	011002000492	1
27	Motor Support	01703104	0170310401	1
28	Fan Motor	1501308507	1501308507	1
29	Compressor Overload Protector(External)	00180030	00180030	1
30	Compressor and Fittings	009001000181	009001000030	1
31	Small Handle	26233100	26233100	1
32	Temperature Sensor	3900030805	3900030805	1
33	valve cover	2012300101	2012300101	1

Above data is subject to change without notice.

# 11. Removal Procedure

**⚠ Warning: Be sure to wait for a minimum of 20 minutes after turning off all power supplies and discharge the refrigerant completely before removal.**

## 11.1 Removal Procedure of Indoor Unit

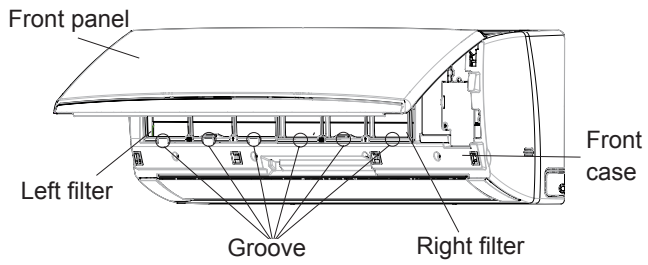
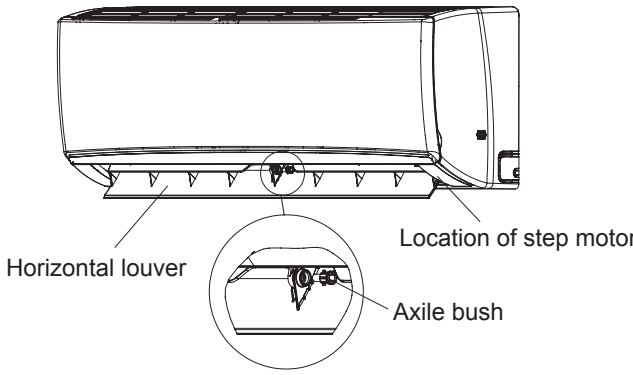
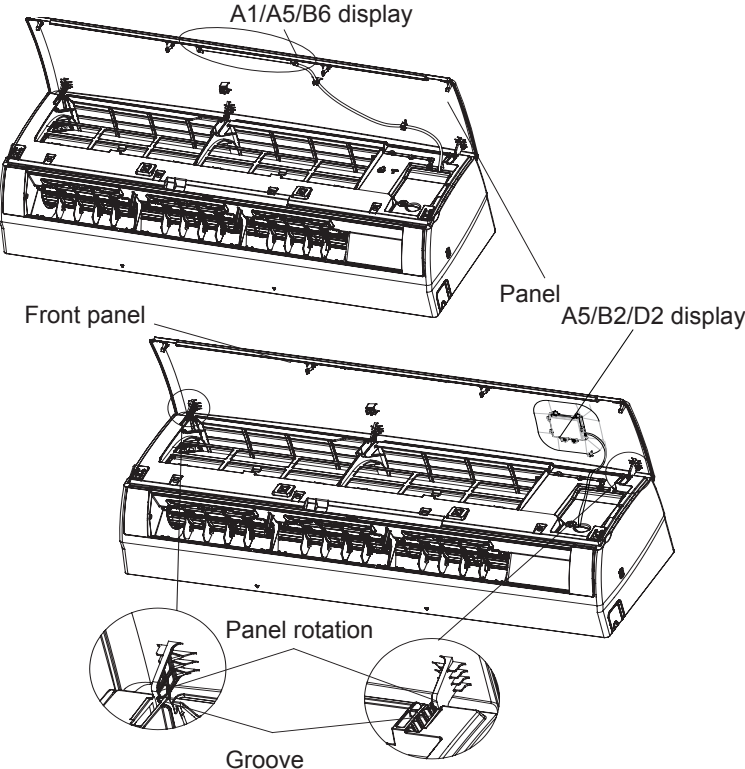
Step	Procedure
1. Remove filter assembly	<p>Open the front panel. Push the left filter and right filter until they are separate from the groove on the front panel. Remove the left filter and right filter respectively.</p> 
2. Remove horizontal louver	<p>Push out the axle bush on horizontal louver. Bend the horizontal louver with hand and then separate the horizontal louver from the crankshaft of step motor to remove it.</p> 
3. Remove panel and display	<p>a</p> <p>(1)A1/A5 panel display: Screw off the 2 screws that are locking the display board. Separate the display board from the front panel.                  (2)B2/A5/D2 panel display: Screw off the 2 screws that are locking the display board.</p> <p>b</p> <p>Separate the panel rotation shaft from the groove fixing the front panel and then removes the front panel.</p> 



Step	Procedure	
4. Remove detecting plate and electric box cover 2	<p>Remove the screw fixing detecting plate and then remove the detecting plate.</p> <p>Note: The position of detection board(WIFI) may be different for -different models.</p> <p>Remove the screw fixing electric box cover 2 and then remove the electric box cover 2.</p>	
5. Remove front case sub-assy	<p>a Remove the screws fixing front case.</p> <p>Note: 1. Open the screw caps before removing the screws around the air outlet. 2. The quantity of screws fixing the front case sub-assy is different for different models.</p> <p>b Loosen the connection clasps between front case sub-assy and bottom case. Lift up the front case sub-assy and take it out.</p>	
6. Remove vertical louver	<p>Loosen the connection clasps between vertical louver and bottom case to remove vertical louver.</p>	

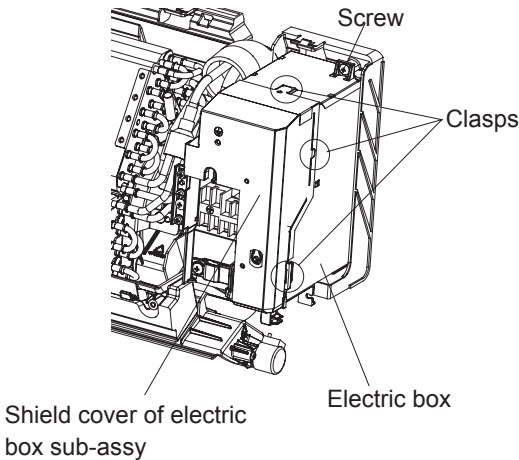
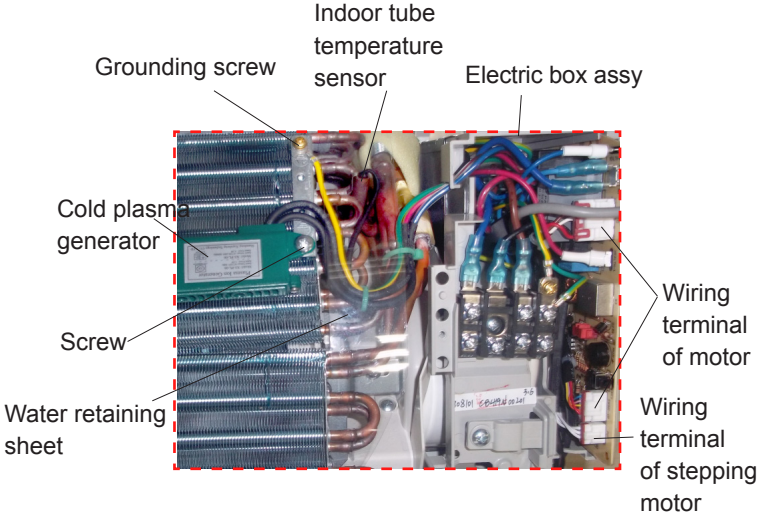
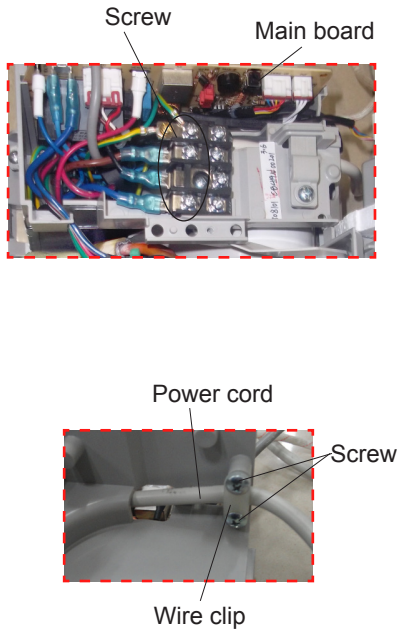

Step	Procedure
7. Remove electric box assy	
a	<p>Loosen the connection clasps between shield cover of electric box sub-assy and electric box, and then remove the shield cover of electric box sub-assy. Remove the screw fixing electric box assy .</p> 
b	<p>① Take off the water retaining sheet. Remove the cold plasma generator by screwing off the locking screw on the generator. ② Take off the indoor tube temperature sensor. ③ Screw off 1 grounding screw. ④ Remove the wiring terminals of motor and stepping motor. ⑤ Remove the electric box assy.</p> 
c	<p>Twist off the screws that are locking each lead wire and rotate the electric box assy. Twist off the screws that are locking the wire clip. Loosen the power cord and remove its wiring terminal. Lift up the main board and take it off.</p> 

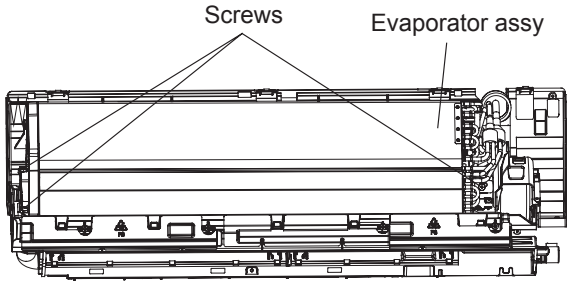
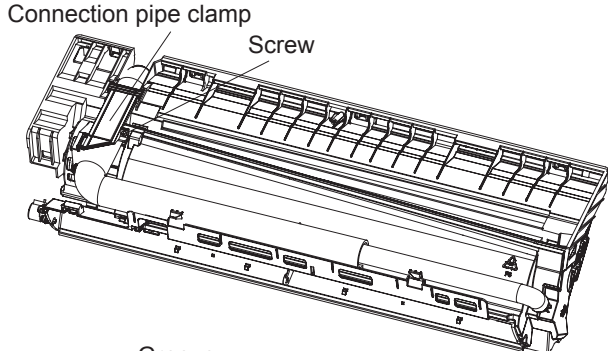
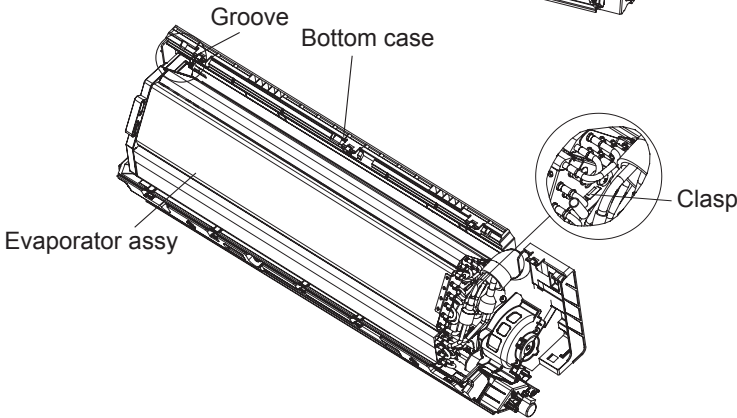
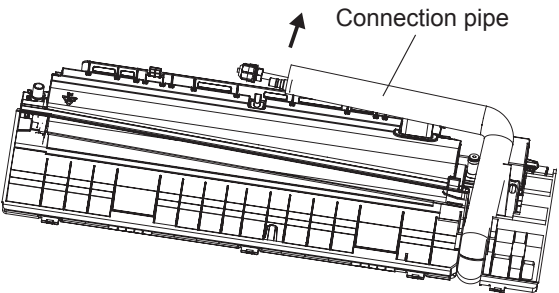
Step	Procedure	
	<p>Instruction: Some wiring terminal of this product is with lock catch and other devices. The pulling method is as below:</p> <ol style="list-style-type: none"> <li>1.Remove the soft sheath for some terminals at first, hold the circlip and then pull out the terminals.</li> <li>2.Pull out the holder for some terminals at first (holder is not available for some wiring terminal), hold the connector and then pull the terminal.</li> </ol>	 <p>Labels: circlip, soft sheath, holder, connector</p>
8. Remove evaporator assy		
a	Remove 3 screws fixing evaporator assy.	 <p>Labels: Screws, Evaporator assy</p>
b	At the back of the unit, remove the screw fixing connection pipe clamp and then remove the connection pipe clamp.	 <p>Labels: Connection pipe clamp, Screw</p>
c	First remove the left side of the evaporator from the groove of bottom case and then remove the right side from the clasp on the bottom case.	 <p>Labels: Groove, Bottom case, Evaporator assy, Clasp</p>
d	Adjust the position of connection pipe on evaporator slightly and then lift the evaporator upwards to remove it.	 <p>Labels: Connection pipe</p>

Step	Procedure
9. Remove motor and cross flow blade	
a	<p>Remove the screws fixing motor clamp and then remove the motor clamp.</p>
b	<p>Remove the screws at the connection place of cross flow blade and motor; lift the motor and cross flow blade upwards to remove them.                      Remove the bearing holder sub-assy.                      Remove the screw fixing step motor and then remove the step motor.</p>

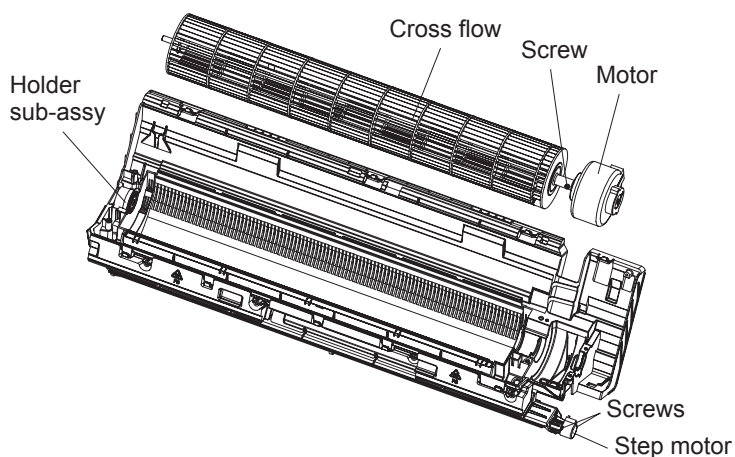
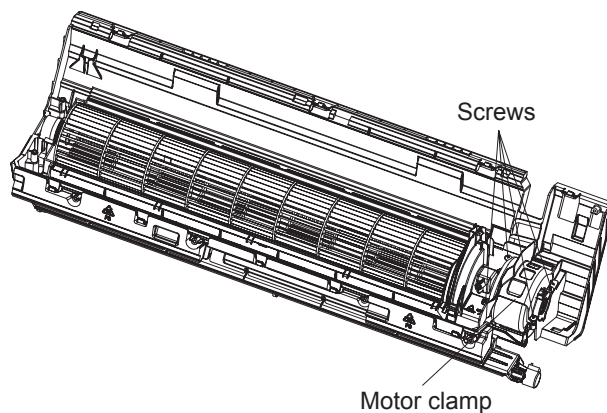

## 11.2 Removal Procedure of Outdoor Unit

**⚠ Warning:** Be sure to wait for a minimum of 20 minutes after turning off all power supplies and discharge the refrigerant completely before removal.

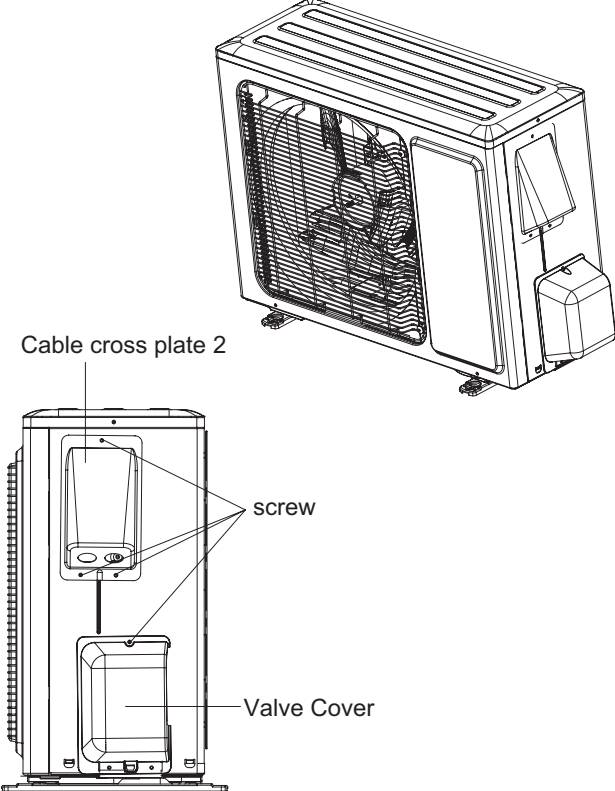
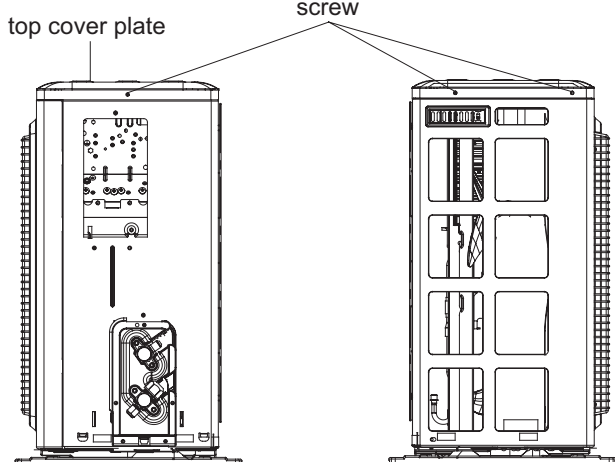
Steps	Procedure
<p><b>1.Remove cable cross plate 2 and valve cover</b></p> <p>Before disassamble.</p> <p>Remove 3 connection screw fixing cable cross plate 2 and then remove the Cable cross plate 2.</p> <p>Remove 1 connection screw fixing valve cover and then remove the valve cover.</p>	
<p><b>2.Remove top cover</b></p> <p>Remove 3 connection screws among top cover plate, front panel and right side plate. Then remove top cover plate.</p>	

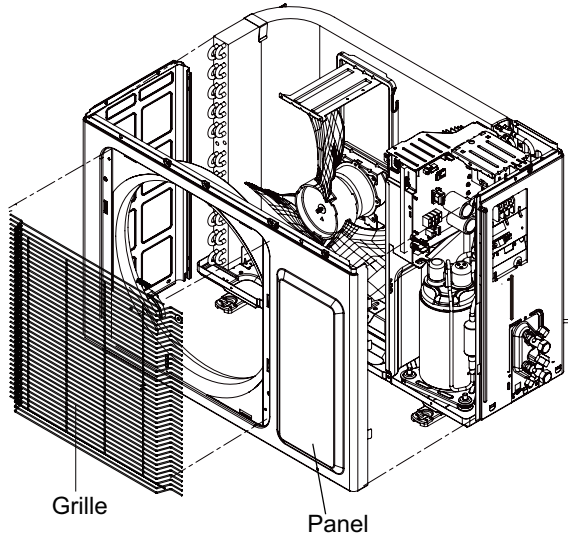
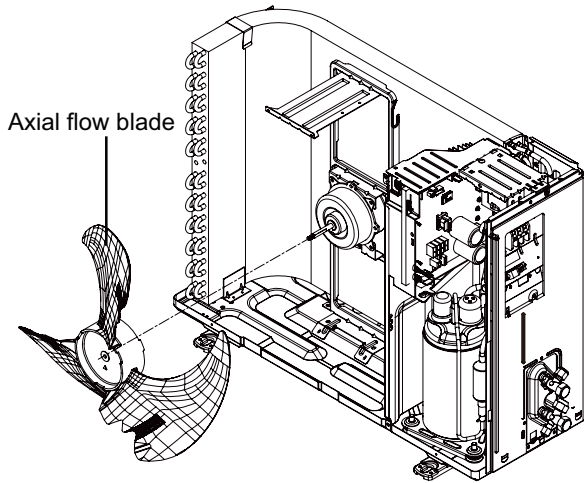
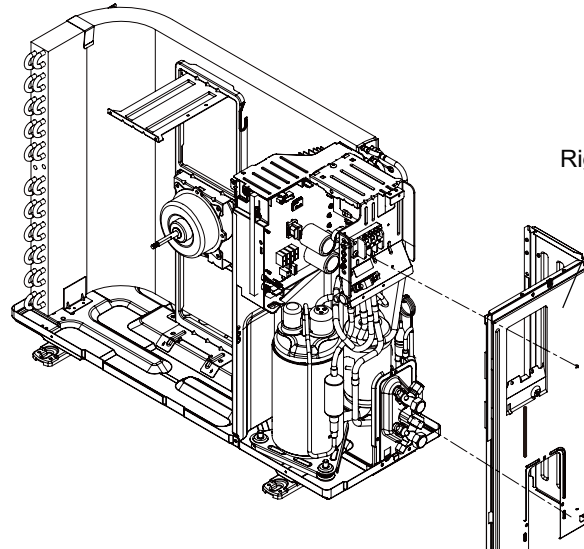
Steps	Procedure
<p><b>3.Remove grille and front panel</b></p>	<p>Remove connection screws between the front grille and the front panel. Then remove the front grille. Remove connection screws connecting the front panel with the chassis and the motor support, and then remove the front panel.</p>  <p>Grille</p> <p>Panel</p>
<p><b>4.Remove axial flow blade</b></p>	<p>Remove the nut fixing the blade and then remove the axial flow blade.</p>  <p>Axial flow blade</p>
<p><b>5.Remove right side plate</b></p>	<p>Remove connection screws connecting the right side plate with the valve support and the electric box. Then remove the right side plate.</p>  <p>Right side plate</p>

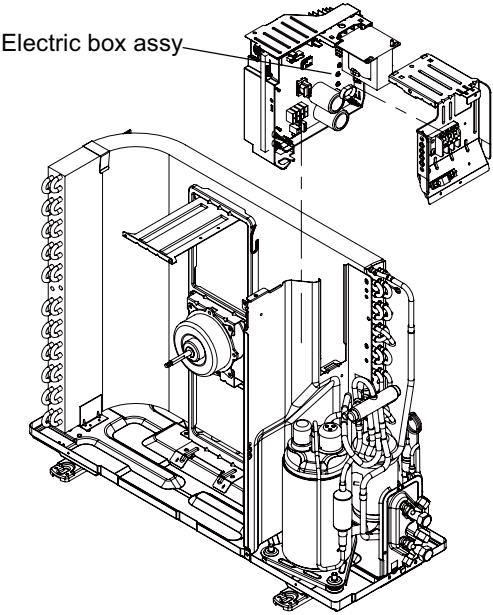
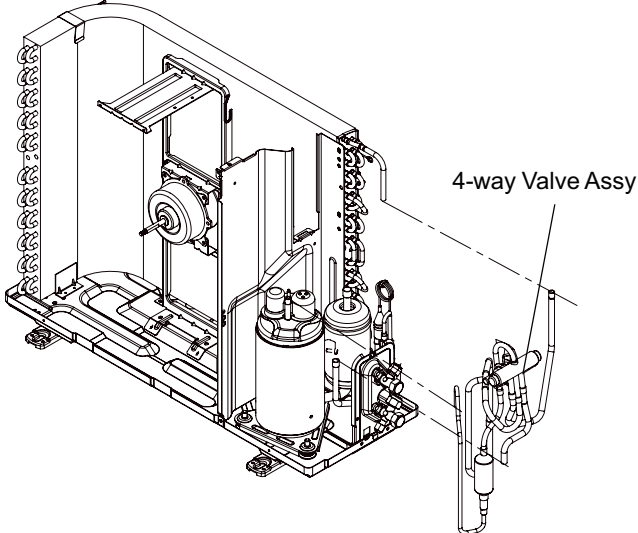
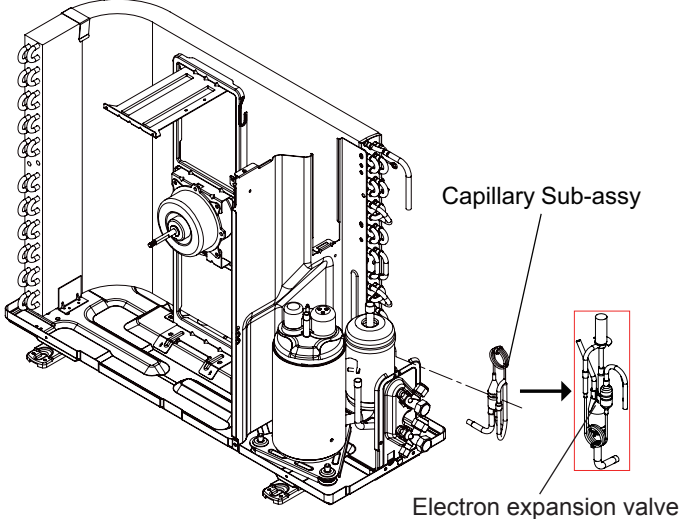
Steps	Procedure
<p><b>6.Remove electric box assy</b></p>	<p>Remove the 2 screws fixing the cover of electric box. Lift to remove the cover. Loosen the wire and disconnect the terminal. Lift to remove the electric box assy.</p>  <p>Electric box assy</p>
<p><b>7.Remove 4-way valve assy</b></p>	<p>Unscrew the fastening nut of the 4-way Valve Assy coil and remove the coil. Wrap the 4-way Valve Assy with wet cotton and unsolder the 4 weld spots connecting the 4-way Valve Assy to take it out.(Note: Refrigerant should be discharged firstly.) Welding process should be as quickly as possible and keep wrapping cotton wet all the time. Be sure not to burn out the lead-out wire of compressor.</p>  <p>4-way Valve Assy</p>
<p><b>8.Remove capillary sub-assy</b></p>	<p>Unsolder weld point of capillary Sub-assy, valve and outlet pipe of condensator. Then remove the capillary Sub-assy. Do not block the capillary when unsoldering it. (Note: before unsoldering, discharge refrigerants completely)</p>  <p>Capillary Sub-assy</p> <p>Electron expansion valve</p>

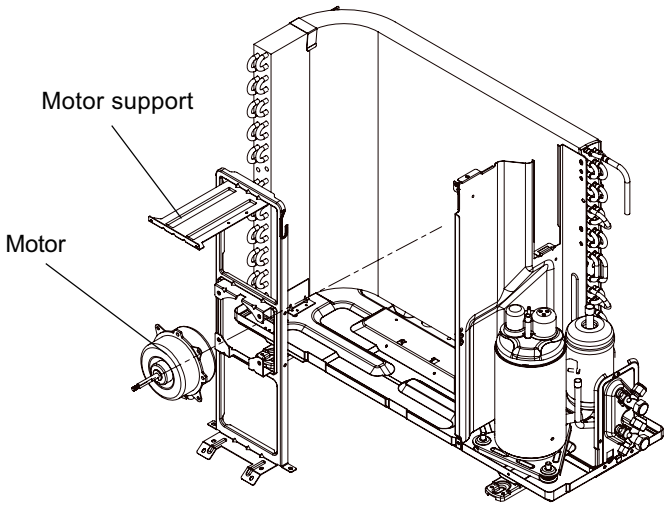
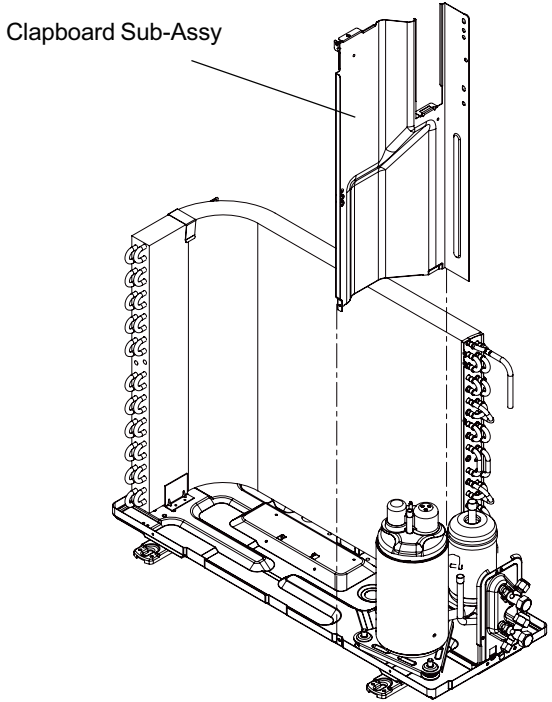

Steps	Procedure
<p><b>9.Remove motor and motor support</b></p>	<p>Remove the 4 tapping screws fixing the motor. Pull out the lead-out wire and remove the motor. Remove the 2 tapping screws fixing the motor support. Lift motor support to remove it.</p> 
<p><b>10.Remove clapboard sub-assy</b></p>	<p>Loosen the screws of the Clapboard Sub-Assy . The Clapboard Sub-Assy has a hook on the lower side. Lift and pull the Clapboard Sub-Assy to remove.</p> 

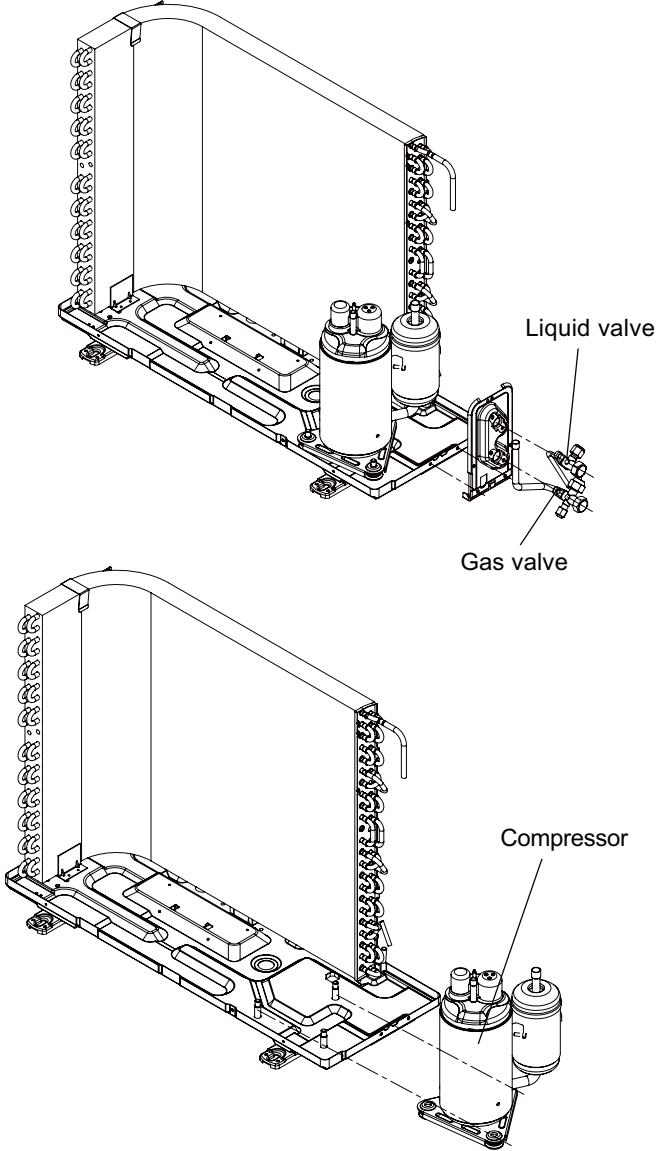
Steps	Procedure
<p><b>11.Remove Compressor</b></p>	 <p>The top diagram illustrates the removal of the gas and liquid valves. It shows a side view of the unit's base with a compressor and valves. Labels point to the 'Liquid valve' and 'Gas valve'. The bottom diagram shows the removal of the compressor, with a label pointing to the 'Compressor'.</p>
<p>a</p>	<p>Remove the 2 screws fixing the gas valve. Unsolder the welding spot connecting gas valve and air return pipe and remove the gas valve. (Note: it is necessary to warp the gas valve when unsoldering the welding spot.) Remove the 2 screws fixing liquid valve. Unsolder the welding spot connecting liquid valve and remove the liquid valve.</p>
<p>b</p>	<p>Remove the 3 footing screws of the compressor and remove the compressor.</p>



## Appendix:

### Appendix 1: Reference Sheet of Celsius and Fahrenheit

Conversion formula for Fahrenheit degree and Celsius degree:  $T_f = T_c \times 1.8 + 32$

Set temperature

Fahrenheit display temperature (°F)	Fahrenheit (°F)	Celsius (°C)	Fahrenheit display temperature (°F)	Fahrenheit (°F)	Celsius (°C)	Fahrenheit display temperature (°F)	Fahrenheit (°F)	Celsius (°C)
61	60.8	16	69/70	69.8	21	78/79	78.8	26
62/63	62.6	17	71/72	71.6	22	80/81	80.6	27
64/65	64.4	18	73/74	73.4	23	82/83	82.4	28
66/67	66.2	19	75/76	75.2	24	84/85	84.2	29
68	68	20	77	77	25	86	86	30

Ambient temperature

Fahrenheit display temperature (°F)	Fahrenheit (°F)	Celsius (°C)	Fahrenheit display temperature (°F)	Fahrenheit (°F)	Celsius (°C)	Fahrenheit display temperature (°F)	Fahrenheit (°F)	Celsius (°C)
32/33	32	0	55/56	55.4	13	79/80	78.8	26
34/35	33.8	1	57/58	57.2	14	81	80.6	27
36	35.6	2	59/60	59	15	82/83	82.4	28
37/38	37.4	3	61/62	60.8	16	84/85	84.2	29
39/40	39.2	4	63	62.6	17	86/87	86	30
41/42	41	5	64/65	64.4	18	88/89	87.8	31
43/44	42.8	6	66/67	66.2	19	90	89.6	32
45	44.6	7	68/69	68	20	91/92	91.4	33
46/47	46.4	8	70/71	69.8	21	93/94	93.2	34
48/49	48.2	9	72	71.6	22	95/96	95	35
50/51	50	10	73/74	73.4	23	97/98	96.8	36
52/53	51.8	11	75/76	75.2	24	99	98.6	37
54	53.6	12	77/78	77	25			

### Appendix 2: Configuration of Connection Pipe

- Standard length of connection pipe. (More details please refer to the specifications)
- Min. length of connection pipe is 9.84ft.
- Max. length of connection pipe and max. high difference. (More details please refer to the specifications)
- The additional refrigerant oil and refrigerant charging required after prolonging connection pipe
  - After the length of connection pipe is prolonged for 32.81ft at the basis of standard length, you should add 0.0013gal of refrigerant oil for each additional 16.40ft of connection pipe.
  - The calculation method of additional refrigerant charging amount (on the basis of liquid pipe):
  - Basing on the length of standard pipe, add refrigerant according to the requirement as shown in the table. The additional refrigerant charging amount per meter is different according to the diameter of liquid pipe. See the following sheet.
  - Additional refrigerant charging amount = prolonged length of liquid pipe X additional refrigerant charging amount per meter

Additional refrigerant charging amount for R22, R407C, R410A and R134a			
Diameter of connection pipe		Outdoor unit throttle	
Liquid pipe (inch)	Gas pipe (inch)	Cooling only (oz/ft.)	Cooling and heating (oz/ft.)
Φ1/4	Φ3/8 or Φ1/2	0.2	0.2
Φ1/4 or Φ3/8	Φ5/8 or Φ3/4	0.2	0.6
Φ1/2	Φ3/4 or Φ7/8	0.3	1.3
Φ5/8	Φ1 or Φ1 1/4	0.7	1.3
Φ3/4	/	2.7	2.7
Φ7/8	/	3.8	3.8

## Appendix 3: Pipe Expanding Method

**⚠ Note:**

**Improper pipe expanding is the main cause of refrigerant leakage. Please expand the pipe according to the following steps:**

**A: Cut the pipe**

- Confirm the pipe length according to the distance of indoor unit and outdoor unit.
- Cut the required pipe with pipe cutter.

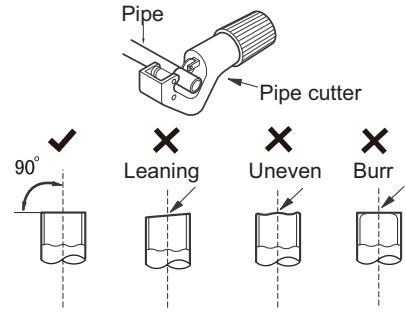

**B: Remove the burrs**

- Remove the burrs with shaper and prevent the burrs from getting into the pipe.

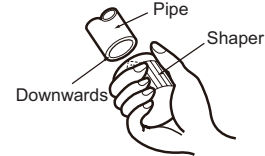

**C: Put on suitable insulating pipe**

**D: Put on the union nut**

- Remove the union nut on the indoor connection pipe and outdoor valve; install the union nut on the pipe.

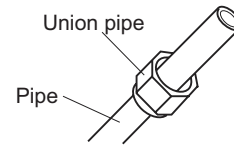

**E: Expand the port**

- Expand the port with expander.

**⚠ Note:**

- "A" is different according to the diameter, please refer to the sheet below:

Outer diameter(inch)	A(inch)	
	Max	Min
Φ0.24 - 0.25 (1/4")	0.05	0.03
Φ0.37 (3/8")	0.06	0.04
Φ0.47 - 0.50 (1/2")	0.07	0.04
Φ0.63 - 0.625 (5/8")	0.09	0.09

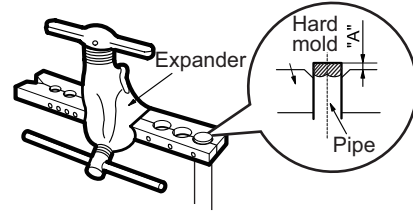

**F: Inspection**

- Check the quality of expanding port. If there is any blemish, expand the port again according to the steps above.

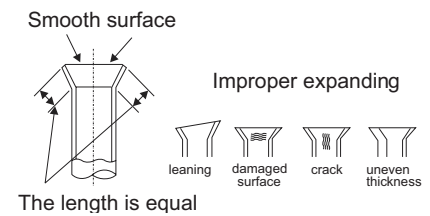

## Appendix 4: List of Resistance for Temperature Sensor

Resistance Table of Ambient Temperature Sensor for Indoor and Outdoor(15K)

Temp.(°F)	Resistance(kΩ)	Temp.(°F)	Resistance(kΩ)	Temp.(°F)	Resistance(kΩ)	Temp.(°F)	Resistance(kΩ)
-2.2	138.1	68	18.75	138.2	3.848	208.4	1.071
-0.4	128.6	69.8	17.93	140	3.711	210.2	1.039
1.4	121.6	71.6	17.14	141.8	3.579	212	1.009
3.2	115	73.4	16.39	143.6	3.454	213.8	0.98
5	108.7	75.2	15.68	145.4	3.333	215.6	0.952
6.8	102.9	77	15	147.2	3.217	217.4	0.925
8.6	97.4	78.8	14.36	149	3.105	219.2	0.898
10.4	92.22	80.6	13.74	150.8	2.998	221	0.873
12.2	87.35	82.4	13.16	152.6	2.896	222.8	0.848
14	82.75	84.2	12.6	154.4	2.797	224.6	0.825
15.8	78.43	86	12.07	156.2	2.702	226.4	0.802
17.6	74.35	87.8	11.57	158	2.611	228.2	0.779
19.4	70.5	89.6	11.09	159.8	2.523	230	0.758
21.2	66.88	91.4	10.63	161.6	2.439	231.8	0.737
23	63.46	93.2	10.2	163.4	2.358	233.6	0.717
24.8	60.23	95	9.779	165.2	2.28	235.4	0.697
26.6	57.18	96.8	9.382	167	2.206	237.2	0.678
28.4	54.31	98.6	9.003	168.8	2.133	239	0.66
30.2	51.59	100.4	8.642	170.6	2.064	240.8	0.642
32	49.02	102.2	8.297	172.4	1.997	242.6	0.625
33.8	46.6	104	7.967	174.2	1.933	244.4	0.608
35.6	44.31	105.8	7.653	176	1.871	246.2	0.592
37.4	42.14	107.6	7.352	177.8	1.811	248	0.577
39.2	40.09	109.4	7.065	179.6	1.754	249.8	0.561
41	38.15	111.2	6.791	181.4	1.699	251.6	0.547
42.8	36.32	113	6.529	183.2	1.645	253.4	0.532
44.6	34.58	114.8	6.278	185	1.594	255.2	0.519
46.4	32.94	116.6	6.038	186.8	1.544	257	0.505
48.2	31.38	118.4	5.809	188.6	1.497	258.8	0.492
50	29.9	120.2	5.589	190.4	1.451	260.6	0.48
51.8	28.51	122	5.379	192.2	1.408	262.4	0.467
53.6	27.18	123.8	5.197	194	1.363	264.2	0.456
55.4	25.92	125.6	4.986	195.8	1.322	266	0.444
57.2	24.73	127.4	4.802	197.6	1.282	267.8	0.433
59	23.6	129.2	4.625	199.4	1.244	269.6	0.422
60.8	22.53	131	4.456	201.2	1.207	271.4	0.412
62.6	21.51	132.8	4.294	203	1.171	273.2	0.401
64.4	20.54	134.6	4.139	204.8	1.136	275	0.391
66.2	19.63	136.4	3.99	206.6	1.103	276.8	0.382

Resistance Table of Tube Temperature Sensors for Indoor and Outdoor (20K)

Temp.(°F)	Resistance(kΩ)	Temp.(°F)	Resistance(kΩ)	Temp.(°F)	Resistance(kΩ)	Temp.(°F)	Resistance(kΩ)
-2.2	181.4	68	25.01	138.2	5.13	208.4	1.427
-0.4	171.4	69.8	23.9	140	4.948	210.2	1.386
1.4	162.1	71.6	22.85	141.8	4.773	212	1.346
3.2	153.3	73.4	21.85	143.6	4.605	213.8	1.307
5	145	75.2	20.9	145.4	4.443	215.6	1.269
6.8	137.2	77	20	147.2	4.289	217.4	1.233
8.6	129.9	78.8	19.14	149	4.14	219.2	1.198
10.4	123	80.6	18.13	150.8	3.998	221	1.164
12.2	116.5	82.4	17.55	152.6	3.861	222.8	1.131
14	110.3	84.2	16.8	154.4	3.729	224.6	1.099
15.8	104.6	86	16.1	156.2	3.603	226.4	1.069
17.6	99.13	87.8	15.43	158	3.481	228.2	1.039
19.4	94	89.6	14.79	159.8	3.364	230	1.01
21.2	89.17	91.4	14.18	161.6	3.252	231.8	0.983
23	84.61	93.2	13.59	163.4	3.144	233.6	0.956
24.8	80.31	95	13.04	165.2	3.04	235.4	0.93
26.6	76.24	96.8	12.51	167	2.94	237.2	0.904
28.4	72.41	98.6	12	168.8	2.844	239	0.88
30.2	68.79	100.4	11.52	170.6	2.752	240.8	0.856
32	65.37	102.2	11.06	172.4	2.663	242.6	0.833
33.8	62.13	104	10.62	174.2	2.577	244.4	0.811
35.6	59.08	105.8	10.2	176	2.495	246.2	0.77
37.4	56.19	107.6	9.803	177.8	2.415	248	0.769
39.2	53.46	109.4	9.42	179.6	2.339	249.8	0.746
41	50.87	111.2	9.054	181.4	2.265	251.6	0.729
42.8	48.42	113	8.705	183.2	2.194	253.4	0.71
44.6	46.11	114.8	8.37	185	2.125	255.2	0.692
46.4	43.92	116.6	8.051	186.8	2.059	257	0.674
48.2	41.84	118.4	7.745	188.6	1.996	258.8	0.658
50	39.87	120.2	7.453	190.4	1.934	260.6	0.64
51.8	38.01	122	7.173	192.2	1.875	262.4	0.623
53.6	36.24	123.8	6.905	194	1.818	264.2	0.607
55.4	34.57	125.6	6.648	195.8	1.736	266	0.592
57.2	32.98	127.4	6.403	197.6	1.71	267.8	0.577
59	31.47	129.2	6.167	199.4	1.658	269.6	0.563
60.8	30.04	131	5.942	201.2	1.609	271.4	0.549
62.6	28.68	132.8	5.726	203	1.561	273.2	0.535
64.4	27.39	134.6	5.519	204.8	1.515	275	0.521
66.2	26.17	136.4	5.32	206.6	1.47	276.8	0.509

Resistance Table of Discharge Temperature Sensor for Outdoor(50K)

Temp.(°F)	Resistance(kΩ)	Temp.(°F)	Resistance(kΩ)	Temp.(°F)	Resistance(kΩ)	Temp.(°F)	Resistance(kΩ)
-20.2	853.5	50	98	120.2	18.34	190.4	4.754
-18.4	799.8	51.8	93.42	122	17.65	192.2	4.609
-16.6	750	53.6	89.07	123.8	16.99	194	4.469
-14.8	703.8	55.4	84.95	125.6	16.36	195.8	4.334
-13	660.8	57.2	81.05	127.4	15.75	197.6	4.204
-11.2	620.8	59	77.35	129.2	15.17	199.4	4.079
-9.4	580.6	60.8	73.83	131	14.62	201.2	3.958
-7.6	548.9	62.6	70.5	132.8	14.09	203	3.841
-5.8	516.6	64.4	67.34	134.6	13.58	204.8	3.728
-4	486.5	66.2	64.33	136.4	13.09	206.6	3.619
-2.2	458.3	68	61.48	138.2	12.62	208.4	3.514
-0.4	432	69.8	58.77	140	12.17	210.2	3.413
1.4	407.4	71.6	56.19	141.8	11.74	212	3.315
3.2	384.5	73.4	53.74	143.6	11.32	213.8	3.22
5	362.9	75.2	51.41	145.4	10.93	215.6	3.129
6.8	342.8	77	49.19	147.2	10.54	217.4	3.04
8.6	323.9	78.8	47.08	149	10.18	219.2	2.955
10.4	306.2	80.6	45.07	150.8	9.827	221	2.872
12.2	289.6	82.4	43.16	152.6	9.489	222.8	2.792
14	274	84.2	41.34	154.4	9.165	224.6	2.715
15.8	259.3	86	39.61	156.2	8.854	226.4	2.64
17.6	245.6	87.8	37.96	158	8.555	228.2	2.568
19.4	232.6	89.6	36.38	159.8	8.268	230	2.498
21.2	220.5	91.4	34.88	161.6	7.991	231.8	2.431
23	209	93.2	33.45	163.4	7.726	233.6	2.365
24.8	198.3	95	32.09	165.2	7.47	235.4	2.302
26.6	199.1	96.8	30.79	167	7.224	237.2	2.241
28.4	178.5	98.6	29.54	168.8	6.998	239	2.182
30.2	169.5	100.4	28.36	170.6	6.761	240.8	2.124
32	161	102.2	27.23	172.4	6.542	242.6	2.069
33.8	153	104	26.15	174.2	6.331	244.4	2.015
35.6	145.4	105.8	25.11	176	6.129	246.2	1.963
37.4	138.3	107.6	24.13	177.8	5.933	248	1.912
39.2	131.5	109.4	23.19	179.6	5.746	249.8	1.863
41	125.1	111.2	22.29	181.4	5.565	251.6	1.816
42.8	119.1	113	21.43	183.2	5.39	253.4	1.77
44.6	113.4	114.8	20.6	185	5.222	255.2	1.725
46.4	108	116.6	19.81	186.8	5.06	257	1.682
48.2	102.8	118.4	19.06	188.6	4.904	258.8	1.64



JF00302638

